

Factory of Rolling Bearings and Cardan Shafts

Industrijska zona bb  
21235 Temerin  
SERBIA

[www.fkl-serbia.com](http://www.fkl-serbia.com)

Sales Director +381 21 6841 222  
Head of Sales +381 21 6841 190

Sales Managers +381 21 6841 205  
(Foreign Markets) +381 21 6841 201

[sales@fkl-serbia.com](mailto:sales@fkl-serbia.com)

(Domestic Market) +381 21 6841 187

[prodaja@fkl-serbia.com](mailto:prodaja@fkl-serbia.com)

Marketing +381 21 6841 208

[marketing@fkl-serbia.com](mailto:marketing@fkl-serbia.com)



Ball Bearings and Bearing Units





Your partner for

## Providing the Best Solutions





# Table of CONTENTS

## 1. Product information

1.1. Introduction.....	10
1.2. Sealing.....	11
1.3. Lubrication.....	13
1.4. Materials.....	15

## 2. Installation

2.1. Shaft Tolerance and Speed Limit Number.....	18
2.2. Tightening.....	19

## 3. Y Program

3.1. Y-Program advantages.....	22
3.2. Y-Program Designation System.....	22
3.3. Cross References.....	23
3.4. Y-Bearing Units.....	24
3.5. Y-Ball Bearings.....	26
3.6. Ball Bearings with Inch Bore.....	27

## 4. Y-Bearings Data

4.1. Y-Ball Bearings with Grub Screw Locking (UE).....	30
4.2. Y-Ball Bearings with Grub Screw Locking (LE).....	32
4.3. Y-Ball Bearings with Eccentric Locking Collar (UY).....	34
4.4. Y-Ball Bearings with Eccentric Locking Collar (LY).....	36
4.5. Y-Ball Bearings with Integral Adapter Sleeve (UH).....	38
4.6. Y-Ball Bearings with Extended Standard Inner Ring (LS).....	40
4.7. Y-Ball Bearings with Extended Standard Inner Ring (LN).....	41
4.8. Y-Ball Bearings with Standard Inner Ring (US).....	42
4.9. Y-Ball Bearings with Tapered Bore	
Y-Ball Bearings with Adapter Sleeve (LK).....	43
4.10. Y-Ball Bearings with Tapered Bore (UK).....	44
4.11. Y-Ball Bearings with Standard Inner Ring (172).....	45

## 5. Angular Contact Ball Bearing - Double Row..... 47

## 6. Y-Bearing Units Data

6.1. Y-Bearing Plummer Block Units with Grey Cast Iron Housing "S".....	50
6.2. Y-Bearing Plummer Block Units with Grey Cast Iron Housing "V".....	52
6.3. Y-Bearing Plummer Block Units with Grey Cast Iron Housing "U".....	54
6.4. Y-Bearing Flanged Units with Square Grey Cast Iron Housing "F".....	56
6.5. Y-Bearing Flanged Units with Oval Grey Cast Iron Housing "N".....	58

6.6. Y-Bearing Flanged Units with Round Grey Cast Iron Housing "G".....	60
6.7. Y-Bearing Flanged Units with Round Grey Cast Iron Housing "GS".....	62
6.8. Y-Bearing Take - Up Units with Grey Cast Iron Housings "T".....	64
6.9. Y-Bearing Flanged Units with Round Pressed Steel Housing "C".....	66
6.10. Y-Bearing Flanged Units with Triangular Pressed Steel Housing "D".....	68
6.11. Y-Bearing Flanged Units with Oval Pressed Steel Housing "P".....	69

## 7. Agricultural Bearing Units - Special Solutions

7.1. Bearing Units Type 2TB.....	72
7.2. Bearing Units Type 2TC and 2PC.....	73
7.3. ARMOR Bearing Unit.....	74

## 8. Agricultural Bearings and Bearing Units

8.1. Agricultural Bearings	
8.1.1. Round and Square Bore Series with Spherical Outer Ring - Non-Relubricable Type.....	78
8.1.2. Round and Square Bore Series with Cylindrical Outer Ring - Non-Relubricable Type.....	80
8.1.3. Round Bore Series with Spherical and Cylindrical Outer Ring - Relubricable Type.....	82
8.1.4. Square Bore Series with Spherical and Cylindrical Outer Ring - Relubricable Type.....	84
8.1.5. Hexagonal Bore Series with Spherical and Cylindrical Outer Ring.....	86
8.2. Agricultural Bearing Units	
8.2.1. Square Series.....	88
8.2.2. Round Series.....	90
8.3. Agricultural Bearings and Bearing Units Overview.....	91

## 9. Disc Harrow Bearings, Bearing Units and Hubs

9.1. Disc Harrow Bearings and Bearing Units - Independent Discs.....	94
9.2. Integrated Hubs.....	95

## 10. Index Label..... 97

## 11. Production Program..... 98

## 12. FKL Distributors..... 100

# Factory of Rolling Bearings and Cardan Shafts

FKL DOO Temerin is producer of rolling bearings and cardan shafts with tradition in production since 1961. Factory is located in Serbia at area covering 17 hectares. Production zone consists of two production plants in total area of 25.000 m<sup>2</sup>.

With strong focus on the agriculture industry, FKL develops and produces a comprehensive range of solutions for disc harrows, seeding machines, packer rollers, packer ballers, combines as well for the other types of agriculture machinery. By using of advanced lab and field tests FKL can guarantee that every single product is designed to operate from mild to harsh working conditions. FKL's highly skilled technical team is ready to meet all customer demands in order to provide them the most appropriate bearing solution.

Today FKL is being recognized as a high-quality bearing manufacturer all around the world with more than 200 OEM (Original Equipment Manufacturing) references and with spreaded Distribution sales network worldwide.



## Mission

Providing the best solutions and the highest level of service through continuous process of learning and improving.

## Vision

Leading European manufacturer of premium quality bearings and bearing units for agricultural application.

## Our quality has been built on:

- High quality raw material
- Own R&D department
- Highly productive and modernized equipment
- Qualified personnel



FKL DOO Temerin has an **accredited laboratory** for product testing



# Product Information

1.1. Introduction .....	10
1.2. Sealing .....	11
1.3. Lubrication .....	13
1.4. Materials.....	15

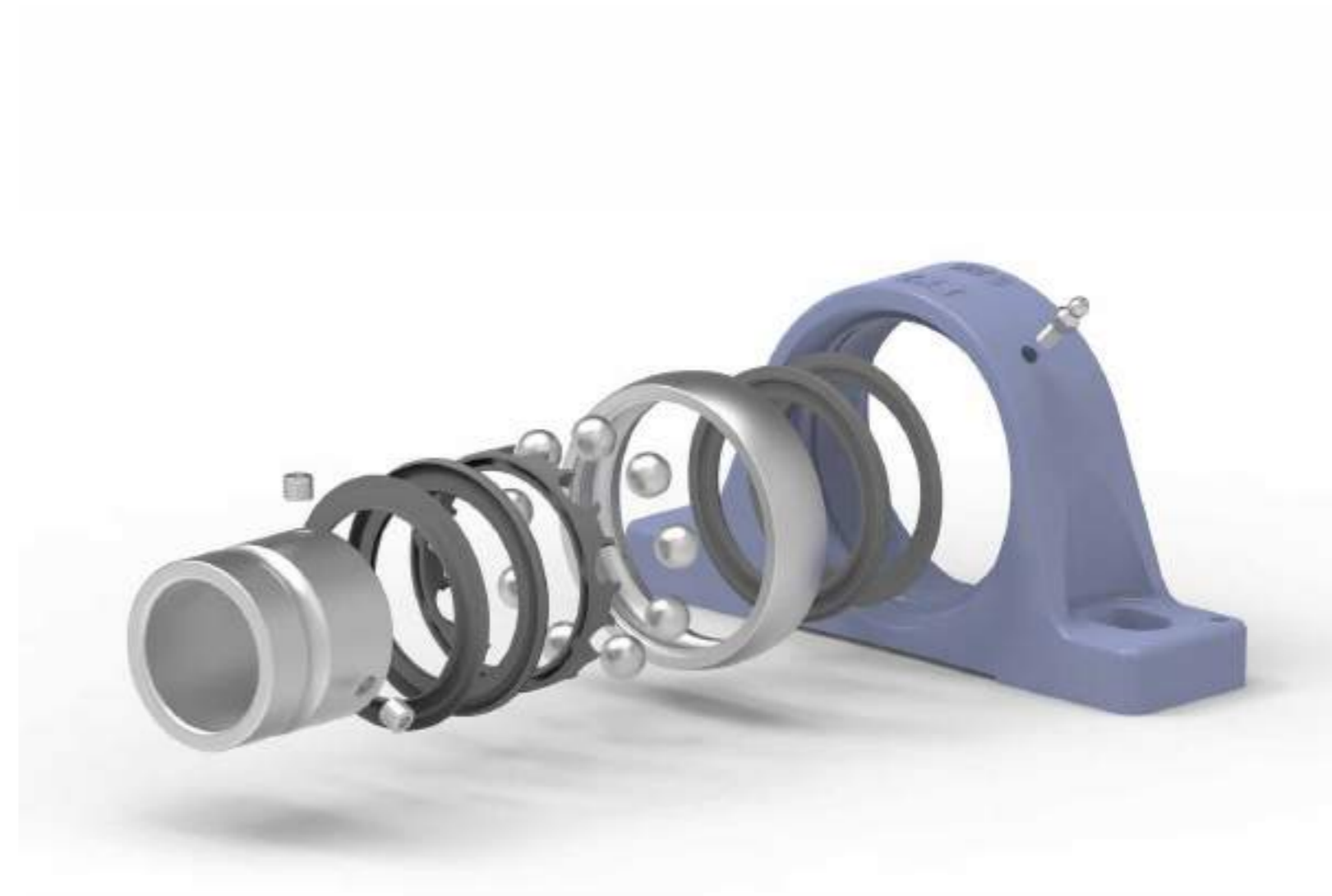

# 1. Product Information

## 1.1. Introduction

This catalog is prepared in order to present all important information about the products and their characteristics in "easy to find" manner.

Whether looking for the particular product, or solution to the specific problem, this catalog represents the choice of most frequent FKL ball bearings and bearing units. This is selection of products that have steady demand, used in a wide range of applications. Our users are familiar with benefits of FKL products. This catalog is primarily designed for end users, so the technical data are reduced to a minimum.

The catalog of ball bearings and bearing units includes designations and principal dimensions for all types of bearings and bearing units that are used to a greater or lesser extent. The catalog also includes an overview of basic production program with comparative designation. The basic designation defines the type of the bearing, size series and the diameter of the bore by the defined order. Suffixes that appear in this catalog and ones that are frequently used are listed and explained in a specified table. Designations of housings follow similar designation system and can be found in the catalog as well. Other European and worldwide producers that are not included in this catalog have similar comparative designations. Additional designations are also specified as well as other necessary explanations.

Technology utilized for the production of the bearings provides significant advantages to customers due to minimal maintenance costs. Each bearing should have longer life span and should operate without any problems during the exploitation. However, it should be noted

that certain external factors affect the quality of bearings as well. They should not be exposed to excessive heat and must be protected from ingress of foreign matter. Also, bearings must be properly lubricated.

This catalog presents bearings designed for agricultural equipment like combine harvesters, harrows, mowers, sugar beet harvesters,... Development of the agricultural industry is followed by development of the cultivation and harvesting machinery. Each stage of cultivation requires special machinery that is either self-propelled or tractor driven, depending on operating conditions. Earlier generations of the machines were equipped with bearings that worked at lower speeds and supported lighter loads.

Modern ball bearings stand up to growing demands of operation in difficult conditions with increased productivity.

Further development trends set demands for longer exploitation life under harsh conditions and more cost-effective design for agricultural machinery. Y-bearings provide cost-effective solutions. They are extensively applied in agricultural machinery production as well industrial production. These bearings are quick and easy to mount. Wide inner ring can be mounted on the shaft by the eccentric ring, screws or adapter sleeves. Seals are specially designed and fitted to the outer ring. The advantages of these bearings have led to their rapid adoption by manufacturers of agricultural machinery.

Each FKL bearing is produced in accordance with strict premium quality standards.

## 1.2. Sealing

FKL offers economical and space-saving sealing solutions. Bearings can have shields and/or seals at one or both sides. Bearings that are sealed at both sides can be re-lubricating or maintenance-free. Sealed bearings are generally used where sufficiently effective external sealing cannot be provided due to inadequate space or cost effectiveness. Bearings fitted with shields are used where the possibility of impurity ingress is low and there is no danger of water or steam contact with the bearings or where high speed or operating temperature of the bearings is required. Bearings fitted with contact seals are preferred to be used where contamination is moderate and where moisture, water, steam may occur or where a long exploitation life without maintenance is required.

### Bearing sealing

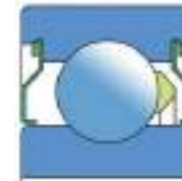

**Fig. 1 Sealing 2Z**

Non-contact sealing with Steel sheet shield of simple and cheap make. Grease prevents penetration of rough impurities. Allows the highest speeds. It is used with the deep groove ball bearings.

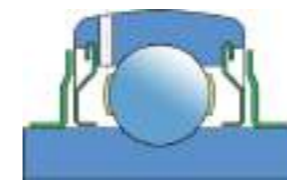

**Fig. 2 Sealing 2L**

Non-contact sealing improved with the sheet steel shields, which prevent the penetration of the rough impurities and lengthen the labyrinth. With the help of grease, a rather good sealing has been achieved. It permits the highest speeds. It is used with Y-bearings (special requests).



**Fig. 3 Sealing 2RS**

The older type of the single seal. Prevents penetration of soil, dust and water and since exposed to the impact of abrasive particles is expendable more than some new types of seals. Due to extended friction, the permitted speeds are lower. It was gradually replaced with the improved versions of (2S). Because of the traditional reasons Y bearings with this kind of seal do not have the additional sealing mark. It is used with the Y-bearings and deep groove ball bearings.

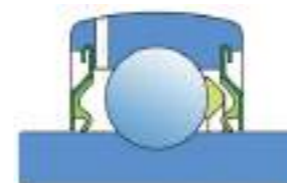

**Fig. 4 Sealing 2S**

Single seal with the labyrinth between the sheet part and the rubber lip which conducts the contact sealing. The friction and speeds are the same as with 2RS but provides much better protection against the rough impurity particles. This is very good sealing system: the sheet part protects the seal from the soil, dust and rough particles. At the same time makes the labyrinth with the rubber part. The rubber part provides contact sealing which prevents penetration of finer impurities, water, moisture, steam etc. Suitable for neutral conditions because of the presence of the foreign materials. It is used with the Y bearing (standard) and deep groove ball bearings.

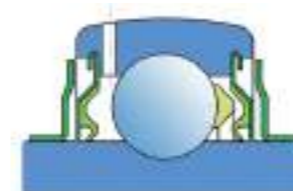

**Fig. 5 Sealing 2F**

Dual sealing, protection cover placed on the inner ring protects against rough impurity particles and makes the labyrinth with the sheet part of the seal; then the sealing 2S type, with the labyrinth between the sheet part and the rubber lip that conducts the contact sealing. The friction and speeds are the same as with 2S but has much better protection against rough impurity particles. It is very good sealing system: the sheet part protects the seal from the soil, dust and rough particles. At the same time makes the labyrinth with the rubber part. The rubber part provides the contact sealing that prevents the penetration of the finer impurities, water, moisture, steam etc. Suitable for heavier conditions due to better protection against foreign matters. It is used with the Y bearings (standard).

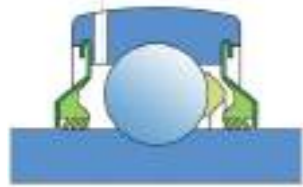

**Fig. 6 Sealing 2T**

By construction is the same as 2S, except rubber lip is tripled. Therefore, it seals better but has even larger friction. The permitted speeds are much lower, up to 500 rpm. It emerges out of external ring width and is applied only with special bearings for the agricultural machines (practically standard sealing for the disc harrow bearings) and to the less extent, Y - bearing program (delivery is made according to special request). Additional protection provided by metal-sheet cap is also available (designation 2TC).

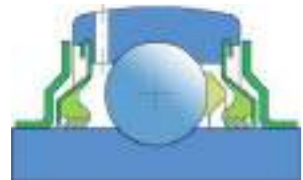

**Fig. 7 Sealing 2TB**

Dual sealing, combination 2T and stronger protection steel. Friction and speeds are the same as 2T, but considerably better protection against rough dirt. This type of sealing is applied in agricultural machinery. Protection steel protects from soil, dust, rough dirt and mechanical impact on the seal. Triple-lips seal performs contact sealing that prevents penetration of finer dirt, water, damp etc. Suitable for difficult working conditions with aggressive presence of foreign matter. Used with Y bearing units 2TB.



**Fig. 8 Sealing 2P**

By construction is the similar as 2T, except rubber lip is fivefold. Therefore, it seals better but has even larger friction. The permitted speeds are much lower, up to 500 rpm. It emerges out of external ring width and is applied only with special bearings for the agricultural machines (practically standard sealing for the disc harrow bearings) and to the less extent, Y - bearing program (delivery is made according to special request). Additional protection provided by metal-sheet cap is also available (designation 2PC).



**Fig. 9 Sealing 2PB**

Dual sealing, combination 2P and stronger protection steel. Friction and speeds are the same as 2P, but considerably better protection against rough dirt. This type of sealing is applied in agricultural machinery. Protection steel protects from soil, dust, rough dirt and mechanical impact on the seal. Five lip seal performs contact sealing that prevents penetration of finer dirt, water, damp etc. Suitable for difficult working conditions with aggressive presence of foreign matter. Used with Y bearing units according to special request.



**Fig. 10 Sealing TDT**

Additional metal cover with thickness of 1 mm provides reliable mechanical protection. Unique combination of six-lip sealing, double 3 lip sealing protects bearing from the outer side, one 3 lip sealing protects bearing from inner side. This presents today the best sealing system for application in agricultural machinery.



**Fig. 11 Dirtblock Sealing**

Designed for hard working condition at unfriendly environment. Half metal - half rubber outside diameter provides reliable seal retention in the bore and improves sealing performance. Inside diameter is covered by rubber and improves sealing performance and easy installation. This sealing provides maximum protection against liquid or solid contaminants, which significantly extends bearing service life.

## 1.3. Lubrication

FKL bearings and bearing units with integral seals and shields at both sides are sufficiently greased for the lifetime and should not be lubricated, except when used in very harsh working conditions. Standard greases used by FKL DOO Temerin in those products have optimal temperature range and other characteristics suitable for the intended application areas. Filling grades correspond to the bearing size. Relubrication is possible with Y bearings and bearing units supplied with lubricators and corresponding grease channels. FKL DOO Temerin sealed bearings are filled with lithium-grease consistency 2 and cinematic viscosity of basic, mineral oil around 90 mm<sup>2</sup>/s; temperature range of application ranges from -30 up to +120°C.

### Grease lubrication

About 90% of all bearing arrangements are lubricated with grease. Grease has certain advantage comparing to oil because it is easier to retain in the bearing arrangement, particularly with inclined or vertical shafts, and also improves sealing the arrangement against contaminants, moisture or water. However, the shortcoming is lower speeds comparing to oil lubrication. With higher speed bearings, the excess lubricant would cause rapid rise of operating temperature. As a general rule, therefore only the bearing should be completely filled, whilst the free space in the housing should be greased between 30 and 50%. Where the bearings are to operate at very low speed and must be well protected against corrosion, it is advisable to completely fill the housing with grease.

### Lubricating greases

Lubricating greases consist of mineral or synthetic oil combined with a thickener. The thickeners are usually metallic soaps. Additives can also be included to enhance certain characteristics of the grease. The consistency of the grease depends largely on the type and concentration of used thickener. When selecting grease, the viscosity of the base oil, the consistency, operating temperature range and the load carrying ability are the most important factors to be considered.

### Base oil viscosity

The base oil viscosity of the greases normally used for rolling bearings lies between 15 and 500 mm<sup>2</sup>/s at 40°C. Greases based on oils having higher viscosities than 1000 mm<sup>2</sup>/s at 40°C bleed oil so slowly that the bearing will not be adequately lubricated. Therefore, if a very high viscosity is required because of low speeds, oil lubrication will generally be found more reliable. The base oil viscosity also governs the maximum permissible speed at which given grease can be

used for bearing lubrication. For applications operating at very high speeds, the most suitable greases are those incorporating diester oils of low viscosity. The permissible operating speed for grease is also influenced by the shear strength of the grease, which is determined by the thickener. "A" is speed factor  $A = n \times d_m$  is often quoted by grease manufacturers to indicate the speed capability; "n" is the rotational speed and "d<sub>m</sub>" is the bearing mean diameter -  $d_m = 0,5(d+D)$ .

### Consistency

Greases are divided into various consistency classes (DIN 51 818), according to the National Lubricating Grease Institute (NLGI) Scale. The consistency of greases used for bearing lubrication should not change unduly according to temperature within the operating temperature range or due to mechanical operation. Greases that soften at elevated temperatures may leak from the bearing arrangement. Those that stiffen at low temperatures may restrict rotation of the bearing. Metallic soap thickened greases of consistency 1, 2 or 3 are those normally used for rolling bearings. The consistency 3 greases are primarily recommended for bearing arrangements with vertical shafts.

### Protection against corrosion

The grease rust inhibiting characteristics are mainly determined by the rust inhibitors which are added to the grease and its thickener. Grease should provide protection to the bearing against corrosion and should not be washed out of the bearing in case of water penetration. These two features are possessed by lithium and calcium based greases containing lead base additives. However, because of environmental and health reasons such additives are being replaced by other combinations of additives which do not always provide lubricant with such good features.

### Load carrying ability

For heavily loaded bearings, e.g. rolling mill bearings, it has been accustomed to recommend the use of greases containing EP additives, since those additives increase the load carrying ability of the lubricant film. Originally, most EP additives were lead-based compounds and there were arguments suggesting benefits in bearing life extension where lubrication was otherwise poor without elastic-hydrodynamic lubricant film.

## Miscibility

Some greases are incompatible and if mixed together the consistency can change dramatically as well as allowed operating temperature. Greases having the same thickener and similar base oils can generally be mixed without any consequences. Lithium and calcium base greases are generally miscible with each other but not with sodium base greases. However, mixtures of compatible greases may have a consistency which is less than either of the component greases, although the lubricating characteristics are not necessarily impaired. In bearing arrangements where a low consistency might lead to grease leakage from the arrangement, the next relubrication should involve complete replacement of the grease rather than replenishment.

## Relubrication

Rolling bearings have to be relubricated if the operating life of the used grease is shorter than the expected life span of the bearing. Relubrication should be performed while lubrication of the bearing is still satisfactory. The time at which relubrication should be undertaken depends on many factors which are related in a complex manner. Those include bearing type and size, speed, operating temperature, grease type, space around the bearing and the bearing environment. The following information is based on long-term tests in various applications but does not apply to applications where water and/or solid contaminants can penetrate the bearing arrangement. In such cases it is recommended that the grease is frequently renewed in order to remove contaminants from the bearing.

## Relubrication intervals

Relubrication intervals  $t_1$ , for normal operating conditions can be calculated as a function of bearing speed "n" and bore diameter "d" of a certain bearing type from Diagram 1. The diagram is valid for bearings on horizontal shafts in stationary machines under normal loads. It applies to good quality lithium base greases at a temperature not exceeding 70°C. To calculate accelerated ageing of grease due to increased temperature it is recommended to split intervals obtained from the diagram by half for every 15°C increase in bearing temperature above 70°C. The intervals may be extended at temperatures lower than 70°C but as operating temperatures decrease the grease will bleed oil less readily and with lower temperatures the extension of intervals by more than two times is not recommended. For bearings on vertical shafts the intervals obtained from the diagram ( $t_1$ ) should be halved. For large roller bearings having "d" of 300 mm and above, the high specific loads in the bearing mean that adequate lubrication will be obtained if the bearing is more frequently relubricated than indicated by the diagram, and the lines are therefore

broken. It is recommended in such cases when continuous lubrication is practiced for technical and economic reasons. The grease quantity to be supplied can be obtained from the equation below:

$$G_k = (0,3 \div 0,5) D \times B \times 10^{-4}$$

where:

$G_k$  - grease quantity to be continuously supplied, g/h

D - bearing outside diameter, mm

B - total bearing width (for thrust bearings use total height "H"), mm

## Relubrication procedures

One of the two procedures described below should be used, depending on the relubrication interval " $t_1$ " obtained:

1. If the relubrication interval is shorter than 6 months, then it is recommended that the grease filling the bearing arrangement should be replenished (topped up) at intervals corresponding to 0,5 " $t_1$ ", the complete grease fill should be replaced after three replenishments, at the latest. Suitable quantities for replenishment can be obtained from:

$$G_p = 0,005 \times D \times B$$

where:

$G_p$  - grease quantity to be added when replenishing, g

D - bearing outside diameter, mm

B - total bearing width (for thrust bearings use total height "H"), mm

2. When lubrication intervals are longer than 6 months it is recommended that all used grease should be removed from the bearing arrangement and replaced by fresh grease.

All these are rough guidelines if there are no specific recommendations by the manufacturer or maintenance service. To facilitate the supply of grease using a grease gun, a grease nipple should be provided on the housing. It is also necessary to provide an exit hole for the grease so that excessive amounts would not build up in the bearing surrounding space. Otherwise it might cause permanent increase in the bearing temperature.

However, as soon as the appropriate temperature is reached after relubrication, the exit hole should be plugged or clogged so the oil bled by the grease could remain at the bearing position. The danger of excess grease collection in the space surrounding the bearing, causing temperature peaking with its detrimental effect on the grease as well as the bearing, is most emphasized when bearing

operates at high speeds. In such cases it is advisable to use a grease discharge valve rather than an exit hole. A grease discharge valve consists basically of a disc which rotates with the shaft and forms a narrow gap with the housing end cover. Excess and used grease is thrown out by the disc into an annular cavity and leaves the housing through an opening on the bottom side of the end cover. To ensure the fresh grease actually reaches the bearing and replaces the old grease, lubrication duct in the housing should either feed the grease adjacent to the outer ringside face or, into the bearing tracks. In general, one

should pay attention to grease density and that it does not remain within the bearing.

## Bearing storage

When bearings are stored in their original packaging, they are corrosion protected for several years. Warehouse humidity should not exceed 60%. In case of sealed bearings, if kept in stock for a long period of time, grease may solidify so after the bearing is mounted, its friction moment is higher in comparison to new bearings. Therefore, this should be taken into consideration.

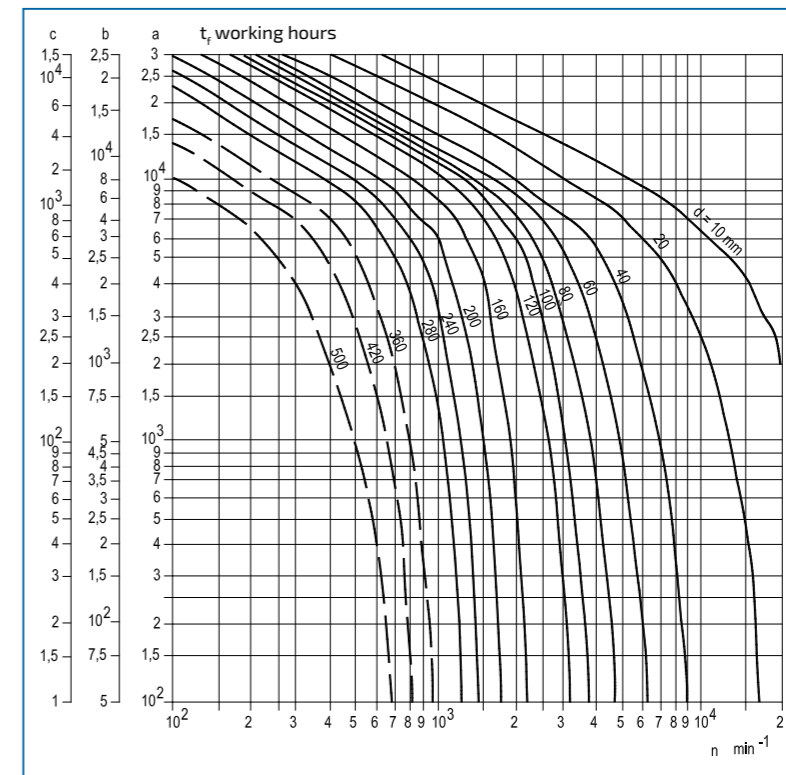

Diagram 1. Relubrication interval

Scale a: deep groove ball bearings

Scale b: cylindrical roller bearings, needle bearings

Scale c: spherical, taper roller bearings, thrust ball bearings

roller bearings – full complement (0,2 t.),

cross-roller bearings with cage (0,3 t.)

thrust roller, needle, spherical bearings (0,5 t.)

## 1.4. Materials

The rings of the bearings and rolling elements are made of special steel (100Cr6 by ISO 683-17:2014) manufactured by the method of vacuum degasification. They are exposed to heat treatment to retain dimensions stability to 150°C. The cages for standard operating temperatures (-20 to +120°C) are made of plastic (ULTRAMID A4H, POLYAMIDE 66). The positive effects of POLYAMIDE, elasticity and small weight, are evident on the high impact bearing load and negative acceleration. The cages of POLYAMIDE possess very good sliding characteristics and steady operation.

The pressed cages are made out of steel sheet. Some massive cages are made of brass. The seals are rubber made (PERBUNAN, BUNA M) and vulcanized onto the sheet guard plate. They can operate in temperature range from -20 to +120°C. Flingers are made of steel sheet. The housings of the Y-bearings are made of cast iron, hardness 200 HB or cold-rolled steel sheet. Grease for common operation temperatures (between -20 and +120°C) is lithium base grease, consistency of the grease 2, viscosity at 40°C is 90 mm<sup>2</sup>/s.



# Installation

2.1. Shaft Tolerance and Speed Limit Number.....	18
2.2. Tightening.....	19



## 2. Installation

### 2.1. Shaft Tolerance and Speed Limit Number

#### Speed ratings

Speed is limited by two factors:

1. By the shaft tolerance on which the bearing is mounted; as tighter fitting is more resistant to shock loads and vibrations and vice versa, fitting with greater clearance is sensitive to those influences and lower speed can be allowed. Recommendations for speed rating, depending on the shaft tolerance, are shown in the Table 1.

2. By the type of sealing because the friction between the sealing and bearing ring increases the operating temperature in proportion to the speed. For normal sealing 2S and 2F data are shown in the following table. For sealing 2B allowed speed is 55 - 60% from that given in the table.

For bearings with three-lip sealing 2T, 2TB and 2TC (bearings for agricultural machinery) allowed speed is max. 500 rpm unless it is lower according to the Table 1.

Bearing type →	UE, LE, UY, LY Shaft tolerances						LK	1726..., LS
	Shaft diameter d	m7, k7	h6	h7	h8	h9		
12	12000	9500	6000	4300	1500	950	-	14000
15	12000	9500	6000	4300	1500	950	-	13000
17	12000	9500	6000	4300	1500	950	-	12000
20	10000	8500	5300	3800	1300	850	7000	10000
25	9000	7000	4500	3200	1000	700	6300	10000
30	7500	6300	4000	2800	900	630	5300	7500
35	6300	5300	3400	2200	750	530	4800	6300
40	5600	4800	3000	1900	670	480	4300	5600
45	5300	4300	2600	1700	600	430	4000	5000
50	4800	4000	2400	1600	560	400	3600	4800
55	4300	3600	2000	1400	500	360	3400	-
60	4000	3400	1900	1300	480	340	3000	-
65	3600	3000	1700	1100	430	300	2600	-
70	3300	2800	1600	1000	400	280	2400	-
80	2800	2400	1400	900	360	240	2200	-
90	2400	2000	1200	800	320	200	-	-
100	2200	1900	1100	750	300	190	-	-
120	1900	1700	900	600	250	160	-	-

Table 1. Speed ratings for Y bearings

### 2.2. Tightening

#### Axial load carrying capacity

Tightening torques for grub screws locking the bearings on the shaft, as well as axial load capacity of shaft-bearing connections are shown in the Table 2.

Shaft diameter (mm)	up to 20	25	30	35	40	45	50	55	60	65	70	75	80	85	90	100	120
Tightening torque (Nm)	4	5	6	12	12	12	23	23	23	23	23	23	23	23	23	23	23
Hook spanner (mm)	3	3	3	4	4	4	5	5	5	5	5	5	6	6	6	6	6
Axial load (kN)	2	3	4	5	6	8	9	10	12	14	14	15	16	16	16	16	16

Table 2. Axial load carrying capacity

# Y-Program

3.1. Y-Program advantages.....	22
3.2. Y-Program Designation System.....	22
3.3. Cross References .....	23
3.4. Y-Bearing Units.....	24
3.5. Y-Ball Bearings.....	26
3.6. Ball Bearings with Inch Bore.....	27



# 3. Y-Program

Y-bearing units are designed to be used in a wide range of applications. They consist of insert ball bearing with spherical outer ring and iron cast or pressed steel housings with spherical internal surface.

Combination of spherical surfaces gives bearing unit possibility of self-aligning.

## 3.1. Y-Program advantages

- Self aligning
- Higher rated load capacity compared to standard bearing units
- Special sealing feature
- Easy mounting
- Secure fitting
- Bearing replaceability
- Available in Maintenance free version or Relubricatable version

## 3.2. Y-Program Designation System

LES 205-100 2F.X

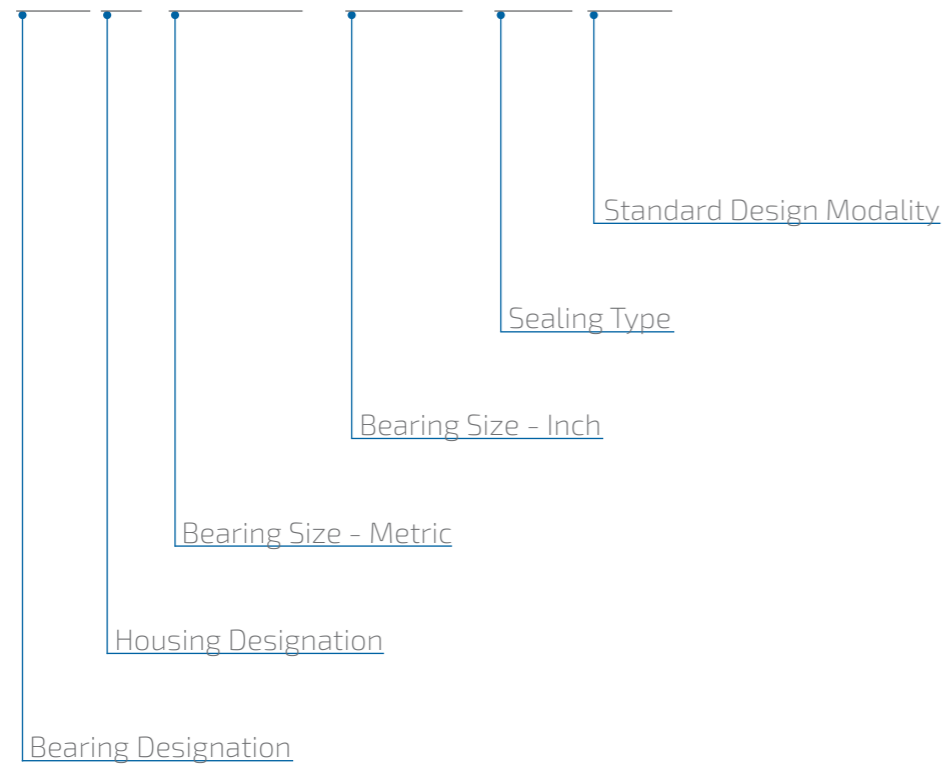

## 3.3. Cross References

CROSS REFERENCES		CROSS REFERENCES													
S	V	U	F	N	G	T	C	D	P	UE	UY	US	UK	LK	LN
SY(J)RM	SYFJRM	SYERM	FYRM	FY(J)RM	FYCRM	TURM	PERM	PERM	PFTRM	UEP	UYE	1726Z)	UK	UK	LN
PASEY	SYFLRM	SYFERM	FYRM	FY(J)RM	FYCRM	TURM	PERM	PERM	PFTRM	UEP	UYE	1726Z)	UK	UK	LN
USP,USPRE	SYFLRM	SYFERM	FYRM	FY(J)RM	FYCRM	TURM	PERM	PERM	PFTRM	UEP	UYE	1726Z)	UK	UK	LN
ASP	ASUP	ASUP	ASF	ASEL	ASEL	LET	LEP	LEP	PFTLF	LEP	UYE	1726Z)	UK	UK	LN
LES	LEV	LEU	LEF	LEN	LEG	LET	LEP	LEP	PFTLF	LEP	UYE	1726Z)	UK	UK	LN
SY(J)TF	SYFTF	SYFTF	FY(J)TF	FY(J)TF	FYCTF	TUJTF	PEJTF	PEJTF	PFTLF	PEJTF	UYE	1726Z)	UK	UK	LN
UCP	UCPA	UCPA	UCF	UCFL	UCFC	UCT	UCFC	UCFC	PFTLF	UCFC	UYE	1726Z)	UK	UK	LN
RASEY	RSHEY	RSHEY	RCY	RCITY	RMHEY	RTUEY	GRRY	GRRY	PFTLF	RTUEY	UYE	1726Z)	UK	UK	LN
UCP,UCPE	UCPA	UCPAE	UCF	UCFL	UCFC	UCT	UCFC	UCFC	PFTLF	UCT	UYE	1726Z)	UK	UK	LN
UCP,DT	UCUP,DT	UCPAE	UCF,DT	UCFL,DT	UCFC,DT	UCT,DT	UCFC,DT	UCFC,DT	PFTLF	UCT,DT	UYE	1726Z)	UK	UK	LN
UCP	UCUP	UCP	UCF	UCFL	UCFC	UCT	UCFC	UCFC	PFTLF	UCT	UYE	1726Z)	UK	UK	LN
UY(S)FM	UY(F)FM	UY(F)FM	UY(F)FM	UY(F)FM	UY(F)FM	UY(F)FM	UY(F)FM	UY(F)FM	PFTLF	UY(F)FM	UYE	1726Z)	UK	UK	LN
PASE	ESPA	PSHE	PCJ	PCIT	PME	PTUE	GRA-RA	RATR	RAT	RATR	UYE	1726Z)	UK	UK	LN
ESP,ESPE	ESPA	ESPAE	ESF	ESFL	ESFC	EST	ESFC	ESFC	ESPFL	ESFC	UYE	1726Z)	UK	UK	LN
AELP	AELUP	AELP	AELF	AELFL	AELFC	AELT	AELPF	AELPF	AELPF	AELPF	UYE	1726Z)	UK	UK	LN
SY(J)WF	SYFJWF	SYFJWF	FY(J)WF	FY(J)WF	FYCFWF	TUJWF	PEJWF	PEJWF	PFTLF	PEJWF	UYE	1726Z)	UK	UK	LN
RASE	RSHE	RSHE	RCJ	RCJT	RME	RTUE	GRA-RA	RATR	RAT	RATR	UYE	1726Z)	UK	UK	LN
EXP,EXPE	EXPA	EXPAE	EXF	EXFL	EXFC	EXT	EXFC	EXFC	ESPFL	EXT	UYE	1726Z)	UK	UK	LN
UEL,DTW3	UELUP,DTW3	EXPAE	UELF,DTW3	UELF,DTW3	UELFC,DTW3	UEL,DTW3	UELFC,DTW3	UELFC,DTW3	ESPFL	UEL,DTW3	UYE	1726Z)	UK	UK	LN
UEL	UEL	UEL	UELF	UELFL	UELFC	UEL	UELFC	UELFC	ESPFL	UEL	UYE	1726Z)	UK	UK	LN
USS	USV	USU	USF	USN	USG	UST	USC	USC	USPFL	USP	UYE	1726Z)	UK	UK	LN
LS	LSV	LSU	LSF	LSN	LSG	LST	LSC	LSC	USPFL	USP	UYE	1726Z)	UK	UK	LN
UKS	UKV	UKU	UKF	UKN	UKG	UKT	UKC	UKC	USPFL	USP	UYE	1726Z)	UK	UK	LN
UKP	UKPA	UKPAE	UKF	UKFL	UKFC	UKT	UKC	UKC	USPFL	USP	UYE	1726Z)	UK	UK	LN
UKP	UKPA	UKPAE	UKF	UKFL	UKFC	UKT	UKC	UKC	USPFL	USP	UYE	1726Z)	UK	UK	LN
LKS	LKV	LKU	LKF	LKN	LKG	LKT	LKC	LKC	USPFL	USP	UYE	1726Z)	UK	UK	LN
SY(J)KF	SYFJKF	SYFJKF	FY(J)KF	FY(J)KF	FYCFKF	TUJKF	PEJKF	PEJKF	USPFL	USP	UYE	1726Z)	UK	UK	LN
UKP	UKPKF	UKPKF	UKF	UKFL	UKFC	UKT	UKC	UKC	USPFL	USP	UYE	1726Z)	UK	UK	LN
RASEA	UKPA	UKPAE	UKF	UKFL	UKFC	UKT	UKC	UKC	USPFL	USP	UYE	1726Z)	UK	UK	LN
UKP,UKPE	UKPA	UKPAE	UKF,DTW3	UKFL,DTW3	UKFC,DTW3	UKT,DTW3	UKC,DTW3	UKC,DTW3	USPFL	USP	UYE	1726Z)	UK	UK	LN
UKP,DTW3	UKUP	UKUP	UKF	UKFL	UKFC	UKT	UKC	UKC	USPFL	USP	UYE	1726Z)	UK	UK	LN
LNS	LNV	LNU	LNF	LNN	LNG	LNT	LNC	LNC	USPFL	USP	UYE	1726Z)	UK	UK	LN
RASEL	RASEL	RASEL	RCIL	RCITL	RCIL	RTUEL	RRL	RRL	USPFL	USP	UYE	1726Z)	UK	UK	LN
GLE,RRRB	GLE	GLE	RRRL	RRRTL	RRRL	RRTRL	RRRL	RRRL	USPFL	USP	UYE	1726Z)	UK	UK	LN

### 3.4. Y-Bearing Units













S	V	U	F	N
203-204-205-206 207-208-209-210 211-212-213-214 215-216-218-220	204-205-206-207 208-209-210	204-205-206-207 208-209-210	203-204-205-206 207-208-209-210 211-212-213-214 215-216-218-220	203-204-205-206 207-208-209-210 211-212
<b>UES</b> 12-15-17-20-25 30-35-40-45-50  mm bore	<b>UEV</b> 20-25-30-35-40 45-50  mm bore	<b>UEU</b> 20-25-30-35-40 45-50  mm bore	<b>UEF</b> 12-15-17-20-25 30-35-40-45-50  mm bore	<b>UEN</b> 12-15-17-20-25 30-35-40-45-50  mm bore
<b>LES</b> 12-15-17-20-25 30-35-40-45-50 55-60-65-70-75 80-90-100  mm bore	<b>LEV</b> 20-25-30-35-40 45-50  mm bore	<b>LEU</b> 20-25-30-35-40 45-50  mm bore	<b>LEF</b> 12-15-17-20-25 30-35-40-45-50 55-60-65-70-75 80-90-100  mm bore	<b>LEN</b> 12-15-17-20-25 30-35-40-45-50 55-60  mm bore
<b>UYS</b> 12-15-17-20-25 30-35-40-45-50 55-60  mm bore	<b>UYV</b> 20-25-30-35-40 45-50  mm bore	<b>UYU</b> 20-25-30-35-40 45-50  mm bore	<b>UYF</b> 12-15-17-20-25 30-35-40-45-50 55-60  mm bore	<b>UYN</b> 12-15-17-20-25 30-35-40-45-50 55-60  mm bore
<b>LYS</b> 12-15-17-20-25 30-35-40-45-50 55-60-65-70-75 80-90-100 mm bore	<b>LYV</b> 20-25-30-35-40 45-50  mm bore	<b>LYU</b> 20-25-30-35-40 45-50  mm bore	<b>LYF</b> 12-15-17-20-25 30-35-40-45-50 55-60-65-70-75 80-90-100 mm bore	<b>LYN</b> 12-15-17-20-25 30-35-40-45-50 55-60  mm bore
<b>USS</b> 17-20-25-30-35 40-45-50-55-60  mm bore	<b>USV</b> 20-25-30-35-40 45-50  mm bore	<b>USU</b> 30-35-40-45-50   mm bore	<b>USF</b> 17-20-25-30-35 40-45-50-55-60  mm bore	<b>USN</b> 17-20-25-30-35 40-45-50-55  mm bore
<b>LSS</b> 25-30-35-40-45 50-55  mm bore	<b>LSV</b> 25-30-35-40-45 50  mm bore	<b>LSU</b> 30-35-40-45-50   mm bore	<b>LSF</b> 25-30-35-40-45 50-55  mm bore	<b>LSN</b> 25-30-35-40-45 50-55  mm bore
<b>UKS</b> 25-30-35-40-45 50-55  mm bore	<b>UKV</b> 25-30-35-40-45 50  mm bore	<b>UKU</b> 30-35-40-45-50   mm bore	<b>UKF</b> 25-30-35-40-45 50-55  mm bore	<b>UKN</b> 25-30-35-40-45 50-55  mm bore
<b>LKS</b> 20-25-30-35-40 45-50-55-60-65 75-80  mm bore	<b>LKV</b> 25-30-35-40-45 50  mm bore	<b>LKU</b> 20-25-30-35-40 45-50  mm bore	<b>LKF</b> 20-25-30-35-40 45-50-55-60-65 75-80  mm bore	<b>LKN</b> 20-25-30-35 40-45-50-55  mm bore



G	T	C	D	P
204-205-206-207 208-209-210-211 212-213	204-205-206-207 208-209-210-211	203-204-205-206 207-208-209-210 211-212	205-206-207	203-204-205-206 207-208
<b>UEG</b> 20-25-30-35-40 45-50  mm bore	<b>UET</b> 20-25-30-35-40 45-50  mm bore	<b>UEC</b> 17-20-25-30-35 40  mm bore	<b>UED</b> 20-25-30-35   mm bore	<b>UEP</b> 17-20-25-30-35 40  mm bore
<b>LEG</b> 20-25-30-35-40 45-50-55-60-65  mm bore	<b>LET</b> 20-25-30-35-40 45-50-55  mm bore	<b>LEC</b> 17-20-25-30-35 40  mm bore	<b>LED</b> 20-25-30-35   mm bore	<b>LEP</b> 17-20-25-30-35 40  mm bore
<b>UYG</b> 20-25-30-35-40 45-50-55-60  mm bore	<b>UYT</b> 20-25-30-35-40 45-50-55  mm bore	<b>UYC</b> 17-20-25-30-35 40  mm bore	<b>UYD</b> 20-25-30-35   mm bore	<b>UYP</b> 17-20-25-30-35 40  mm bore
<b>LYG</b> 20-25-30-35-40 45-50-55-60-65  mm bore	<b>LYT</b> 20-25-30-35-40 45-50-55  mm bore	<b>LYC</b> 17-20-25-30-35 40  mm bore	<b>LYD</b> 20-25-30-35   mm bore	<b>LYP</b> 17-20-25-30-35 40  mm bore
<b>USG</b> 20-25-30-35-40 45-50-55-60  mm bore	<b>UST</b> 20-25-30-35-40 45-50-55  mm bore	<b>USC</b> 20-25-30-35-40   mm bore	<b>USD</b> 17-20-25-30-35   mm bore	<b>USP</b> 20-25-30-35-40   mm bore
<b>LSG</b> 25-30-35-40-45 50-55  mm bore	<b>LST</b> 25-30-35-40-45 50-55  mm bore	<b>LSC</b> 25-30-35-40   mm bore	<b>LSD</b> 25-30-35   mm bore	<b>LSP</b> 25-30-35-40   mm bore
<b>UKG</b> 25-30-35-40-45 50-55-60-65  mm bore	<b>UKT</b> 25-30-35-40-45 50-55  mm bore			
<b>LKG</b> 20-25-30-35-40 45-50-55-60-65  mm bore	<b>LKT</b> 20-25-30-35 40-45-50  mm bore			

### 3.5. Y-Ball Bearings

UE		<b>UE 2..</b> - Inner ring extended on one side only - Grub screw locking - Seals: Metal-rubber seal - Long life lithium/calcium grease
LE		<b>LE 2..</b> - Inner ring extended on both sides - Grub screw locking - Seals: Metal-rubber seal + metal shield - Long life lithium/calcium grease
UY		<b>UY 2..</b> - Inner ring extended on one side only - Eccentric locking collar - Seals: Metal-rubber seal - Long life lithium/calcium grease
LY		<b>LY 2..</b> - Inner ring extended on both sides - Eccentric locking collar - Seals: Metal-rubber seal + metal shield - Long life lithium/calcium grease
UH		<b>UH 2..</b> - Bore reduced one size by adapter sleeve - Standard adapter sleeve series H3(00) - Seals: Metal-rubber seal - Long life lithium-calcium grease - Bearing and adapter sleeve to be ordered together
LS		<b>LS 2..</b> - Inner ring extended on both sides - Locking by interference on the shafts - Seals: Metal-rubber seal + metal shield - Long life lithium/calcium grease
LN		<b>LN 2..</b> - Drive slot in inner ring - Inner ring extended on both sides - Seals: Metal-rubber seal + metal shield - Long life lithium/calcium grease
US		<b>US 2..</b> - Inner ring and outer ring same width - Locking by interference on the shaft - Seals: Metal-rubber seal - Long life lithium/calcium grease
LK		<b>LK 2..+H....</b> - Bore reduced one size by adapter sleeve - Standard adapter sleeve series H23 (00) - Seals: Metal-rubber seal + metal shield - Long life lithium/calcium grease - Bearing and adapter sleeve to be ordered separately
UK		<b>UK 2..+H....</b> - Bore reduced one size by adapter sleeve - Standard adapter sleeve series H23 (00) - Seals: Metal-rubber seal - Long life lithium/calcium grease - Bearing and adapter sleeve to be ordered separately

### 3.6. Ball Bearings with Inch Bore

Hole in Inch	Numerical Designation		Hole in mm
	old	new	
1/2"	201-8	201-008	12.700
9/16"	202-9	202-009	14.2875
5/8"	202-10	202-010	15.8750
11/16"	203-11	203-011	17.6425
3/4"	204-12	204-012	19.0500
13/16"	204-13	205-013	20.6375
7/8"	205-14	205-014	22.2250
15/16"	205-15	205-015	23.8125
1"	205-16	205-100	25.4000
1 1/16"	206-17	206-101	26.9875
1 1/8"	206-18	206-102	28.5750
1 3/16"	206-19	206-103	30.1625
1 1/4"	206-20	206-104	31.7500
1 1/4"	207-20	207-104	31.7500
1 5/16"	207-21	207-105	33.3375
1 3/8"	207-22	207-106	34.9250
1 7/16"	207-23	207-107	36.5125
1 1/2"	208-24	208-108	38.1000
1 9/16"	208-25	208-109	39.6875
1 5/8"	209-26	209-110	41.2750
1 11/16"	209-27	209-111	42.8625
1 3/4"	209-28	209-112	44.4500
1 13/16"	209-29	209-113	46.0375
1 7/8"	210-30	210-114	47.6250
1 15/16"	210-31	210-115	49.2125
2"	211-32	211-200	50.8000
2 1/16"	211-33	211-201	52.3875
2 1/8"	211-34	211-202	53.9750
2 3/16"	211-35	211-203	55.5625
2 1/4"	212-36	212-204	57.1500
2 5/16"	212-37	212-205	58.7375
2 3/8"	212-38	212-206	60.3250
2 7/16"	212-39	212-207	61.9125
2 1/2"	213-40	213-208	63.5000
2 9/16"	214-41	214-209	65.0875
2 5/8"	214-42	214-210	66.675
2 11/16"	214-43	214-211	68.2625
2 3/4"	214-44	214-212	69.8500
2 13/16"	214-45	214-213	71.4375
2 7/8"	215-46	215-214	73.025
2 15/16"	215-47	215-215	74.6125
3"	215-48	215-300	76.2000
3 1/16"	215-49	215-301	77.7875
3 1/8"	216-50	216-302	79.3750
3 3/16"	216-51	216-303	80.9625
3 1/4"	217-52	217-304	82.5500
3 5/16"	217-53	217-305	84.1375
3 3/8"	217-54	217-306	85.725
3 7/16"	217-55	217-307	87.3125
3 1/2"	218-56	218-308	88.9000
3 9/16"	218-57	218-309	90.4875
3 5/8"	218-58	218-310	92.075
3 11/16"	218-59	218-311	93.6625
3 3/4"	220-60	220-312	95.25
3 13/16"	220-61	220-313	96.8375
3 7/8"	220-62	220-314	98.425
3 15/16"	220-63	220-315	100.0125
4"	220-64	220-400	101.6000

# Y-Bearings Data

4.1. UE.....	30
4.2. LE.....	32
4.3. UY.....	34
4.4. LY.....	36
4.5. UH.....	38
4.6. LS.....	40
4.7. LN.....	41
4.8. US.....	42
4.9. LK.....	43
4.10. UK.....	44
4.11. 172.....	45



## 4.1. Y-Ball Bearings with Grub Screw Locking

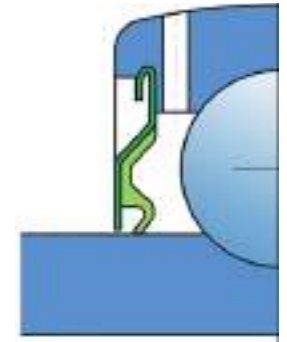
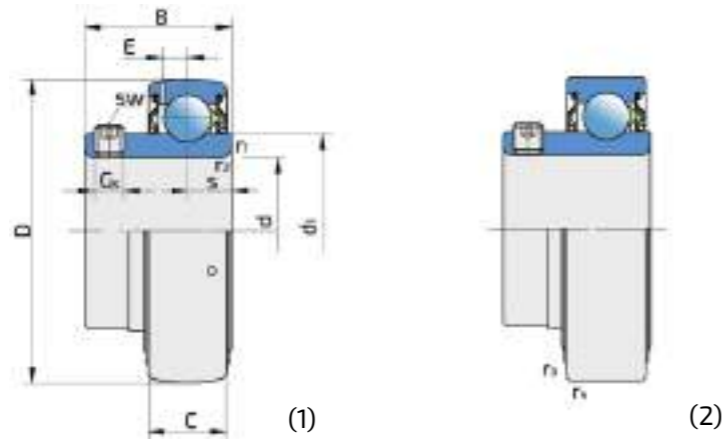

UE...  
UE...SH

Shaft	Dimensions (mm)							
d	D	B	C	s	d <sub>1</sub>	E	Gs	SW
12	40	22.1	12	6.2	24.2	3.6	M6x0.75	3
15								
17								
20	47	25.5	14	7.2	28.2	4.3	M6x0.75	3
25	52	27.2	15	7.7	33.6	4.3	M6x0.75	3
30	62	33	18	9.2	39.7	5.6	M6x0.75	3
35	72	33	19	9.7	46.1	5.6	M6x0.75	3
40	80	36	21	10.7	51.8	6.1	M8x1	4
45	85	37	22	11.2	56.6	6.1	M8x1	4
50	90	38.8	22	11.2	62.5	6.4	M10x1	5

Dimensions (mm)		Load ratings (kN)			Mass	Designation	
r <sub>1,2</sub>	r <sub>3,4</sub>	C <sub>dyn</sub>	C <sub>0</sub>	P <sub>u</sub>	kg	1	2
0.3	0.6	9.56	4.75	0.200	0.09	UE 203/12 2S	UE 203/12 2S.SH
					0.08	UE 203/15 2S	UE 203/15 2S.SH
					0.07	UE 203 2S	UE 203 2S.SH
0.6	0.6	12.7	6.55	0.280	0.11	UE 204 2S	UE 204 2S.SH
0.6	0.6	14	7.8	0.335	0.14	UE 205 2S	UE 205 2S.SH
0.6	0.6	19.5	11.2	0.475	0.23	UE 206 2S	UE 206 2S.SH
1	1	25.5	15.3	0.655	0.31	UE 207 2S	UE 207 2S.SH
1	1.5	30.7	19	0.800	0.43	UE 208 2S	UE 208 2S.SH
1	1.5	33.2	21.6	0.915	0.48	UE 209 2S	UE 209 2S.SH
1	1.5	35.1	23.2	0.980	0.54	UE 210 2S	UE 210 2S.SH

...2S



## 4.2. Y-Ball Bearings with Grub Screw Locking

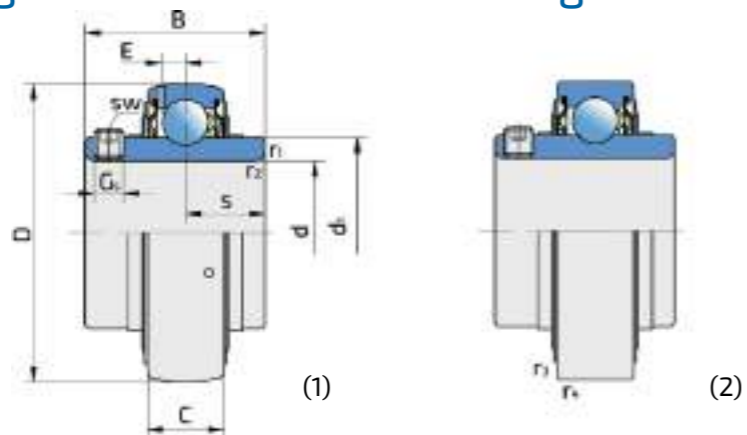

LE...  
LE...SH

Shaft		Dimensions (mm)						
d	D	B	C	s	d <sub>1</sub>	E	Gs	sw
12	40	27.4	12	11.5	24.2	3.6	M6x0.75	3
15								
17								
20	47	31	14	12.7	28.2	4.3	M6x0.75	3
25	52	34.1	15	14.3	33.6	4.3	M6x0.75	3
	62	38	20	15	36.6	5	M6x0.75	3
30	62	38.1	18	15.9	39.7	5.1	M6x0.75	3
	72	43	23	17	44.6	5.6	M6x0.75	3
35	72	42.9	19	17.5	46.1	5.6	M6x0.75	3
	80	48	25	19	49.5	5.7	M8x1	4
40	80	49.2	21	19	51.8	6.1	M8x1	4
	90	52	27	19	56.1	6.1	M10x1	5
45	85	49.2	22	19	56.6	6.1	M8x1	4
	100	57	29	22	62.1	7.1	M10x1	5
50	90	51.6	22	19	62.5	6.4	M10x1	5
	110	61	32	22	68.7	7.9	M12x1.5	6
55	100	55.6	25	22.2	69.1	7	M10x1	5
	120	66	34	25	75.3	8.5	M12x1.5	6
60	110	65.1	26	25.4	75.5	7.7	M10x1	5
	130	71	36	26	81.8	9	M12x1.5	6
65	120	68.3	27	25.4	82.5	7.6	M10x1	5
	140	75	39	30	88.3	9.4	M12x1.5	6
70	125	69.9	28	30.2	87.1	8.1	M10x1	5
	150	78	41	33	94.9	10	M12x1.5	6
75	130	73.3	29	27	92.1	8.3	M10x1	5
80	140	77.8	30	30.2	97.4	8.2	M10x1	5
85	150	81	34	30.2	105	9.3	M12x1.5	6
90	160	89	36	35	112.5	10	M12x1.5	6
	190	96	48	42	121	14.3	M16x1.5	8
100	180	98.4	40	35	112.5	10	M12x1.5	6
	215	108	54	40	121	14.3	M16x1.5	10
110	240	117	60	46	149	18	M18x1.5	10
120	215	73.5	40	28.5	146.4	14	M12x1.5	6
	260	126	64	51	164	19.2	M18x1.5	10

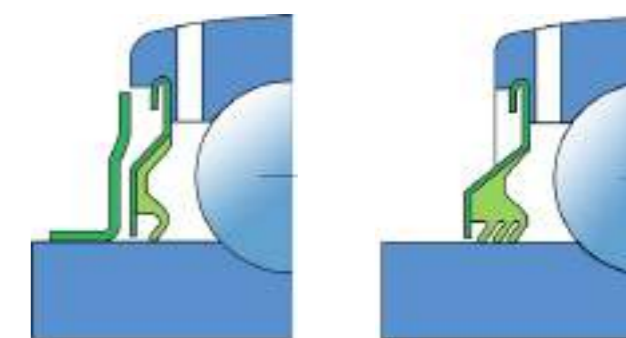

...2F

...2T

Load ratings (kN)					Mass	Designation	
r <sub>1,2</sub>	r <sub>3,4</sub>	C <sub>dyn</sub>	C <sub>0</sub>	P <sub>u</sub>	kg	1	2
0.3	0.6	9.56	4.75	0.200	0.11	LE 203/12 2F	LE 203/12 2F.SH
					0.10	LE 203/15 2F	LE 203/15 2F.SH
					0.09	LE 203 2F	LE 203 2F.SH
0.6	0.6	12.7	6.55	0.280	0.14	LE 204 2F	LE 204 2F.SH
0.6	0.6	14	7.8	0.335	0.17	LE 205 2F	LE 205 2F.SH
1.1	1.1	22.5	11.6	0.490	0.35	LE 305 2F	LE 305 2F.SH
0.6	0.6	19.5	11.2	0.475	0.28	LE 206 2F	LE 206 2F.SH
1.1	1.1	28.1	16	0.670	0.56	LE 306 2F	LE 306 2F.SH
1	1	25.5	15.3	0.655	0.41	LE 207 2F	LE 207 2F.SH
1.5	1.5	33.2	19	0.820	0.71	LE 307 2F	LE 307 2F.SH
1	1	30.7	19	0.800	0.55	LE 208 2F	LE 208 2F.SH
1.5	1.5	41	24	1.020	0.96	LE 308 2F	LE 308 2F.SH
1	1.5	33.2	21.6	0.915	0.60	LE 209 2F	LE 209 2F.SH
1.5	1.5	52.7	31.5	1.340	1.28	LE 309 2F	LE 309 2F.SH
1	1.5	35.1	23.2	0.980	0.69	LE 210 2F	LE 210 2F.SH
2	2	61.8	38	1.600	1.65	LE 310 2F	LE 310 2F.SH
1	2	43.6	29	1.25	0.94	LE 211 2F	LE 211 2F.SH
2	2	71.5	45	1.90	2.07	LE 311 2F	LE 311 2F.SH
1.5	2	52.7	36	1.53	1.30	LE 212 2F	LE 212 2F.SH
2.1	2.1	81.0	52	2.20	2.60	LE 312 2F	LE 312 2F.SH
1.5	2	57.2	40	1.70	1.70	LE 213 2F	LE 213 2F.SH
2.1	2.1	92.3	60	2.50	3.25	LE 313 2F	LE 313 2F.SH
1.5	2	62.4	44	1.86	1.90	LE 214 2F	LE 214 2F.SH
2.1	2.1	104	68	2.75	3.89	LE 314 2F	LE 314 2F.SH
1.5	2	66.3	49	2.04	2.10	LE 215 2F	LE 215 2F.SH
2	2.5	72.8	53	2.16	2.80	LE 216 2F	LE 216 2F.SH
2	2.5	83.2	62	2.50	3.30	LE 217 2F	LE 217 2F.SH
2	2.5	95.6	72	2.70	4.10	LE 218 2F	LE 218 2F.SH
3	3	151	108	3.80	7.87	LE 318 2F	LE 318 2F.SH
2	2.5	124	93	3.35	5.65	LE 220 2F	LE 220 2F.SH
3	3	174	140	4.75	11.2	LE 320 2F	LE 320 2F.SH
3	3	203	180	5.70	15.1	LE 322 2F	LE 322 2F.SH
2	2.5	155	113	3.90	6.20	LE 224 2F	LE 224 2F.SH
3	3	208	186	5.70	19	LE 324 2F	LE 324 2F.SH

### 4.3. Y-Ball Bearings with Eccentric Locking Collar

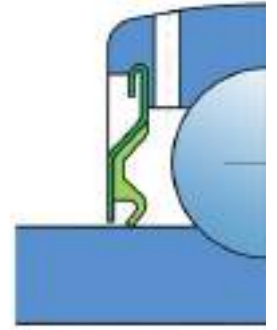
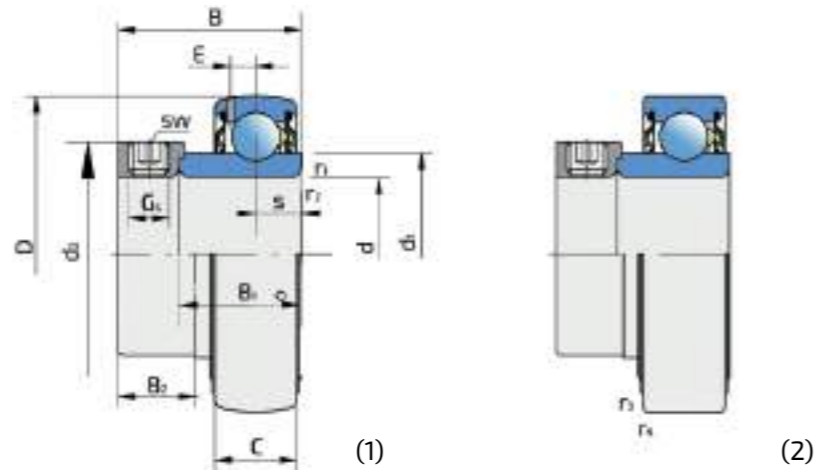

...25

UY...  
UY...SH

Shaft		Dimensions (mm)										
d	D	B	C	s	d <sub>1</sub>	B <sub>1</sub>	d <sub>2</sub>	B <sub>2</sub>	E	Gs	sw	
12	40	28.6	12	6.5	24.2	19.1	28.6	13.5	3.6	M6x0.75	3	
15												
17												
20	47	31	14	7.5	28.2	21.5	33	13.5	4.3	M6x0.75	3	
25	52	31	15	7.5	33.6	21.5	37.4	13.5	4.3	M6x0.75	3	
30	62	35.7	18	9	39.7	23.8	44.2	16	5.1	M8x1	4	
35	72	38.9	19	9.5	46.1	25.4	51.2	17.5	5.6	M10x1	5	
40	80	43.7	21	11	51.8	30.2	58.2	18.3	6.1	M10x1	5	
45	85	43.7	22	11	56.6	30.2	63.6	18.3	6.1	M10x1	5	
50	90	43.7	22	11	62.5	30.2	67.6	18.3	6.4	M10x1	5	
55	100	48.4	25	12.5	69.1	32.5	76.2	20.6	7	M10x1	5	
60	110	53.3	26	13.5	75.5	37.5	84	22.3	7.7	M10x1	5	

Load ratings (kN)					Mass	Designation	
r <sub>1.2</sub>	r <sub>3.4</sub>	C <sub>dyn</sub>	C <sub>0</sub>	P <sub>u</sub>	kg	1	2
0.3	0.6	9.56	4.75	0.200	0.09	UY 203/12 2S	UY 203/12 2S.SH
					0.08	UY 203/15 2S	UY 203/15 2S.SH
					0.07	UY 203 2S	UY 203 2S.SH
0.6	0.6	12.7	6.55	0.280	0.11	UY 204 2S	UY 204 2S.SH
0.6	0.6	14	7.8	0.335	0.14	UY 205 2S	UY 205 2S.SH
0.6	0.6	19.5	11.2	0.475	0.23	UY 206 2S	UY 206 2S.SH
1	1	25.5	15.3	0.655	0.31	UY 207 2S	UY 207 2S.SH
1	1.5	30.7	19	0.800	0.43	UY 208 2S	UY 208 2S.SH
1	1.5	33.2	21.6	0.915	0.48	UY 209 2S	UY 209 2S.SH
1	1.5	35.1	23.2	0.980	0.54	UY 210 2S	UY 210 2S.SH
1	2	43.6	29	1.25	0.98	UY 211 2S	UY 211 2S.SH
1.5	2	52.7	36	1.53	1.3	UY 212 2S	UY 212 2S.SH

## 4.4. Y-Ball Bearings with Eccentric Locking Collar

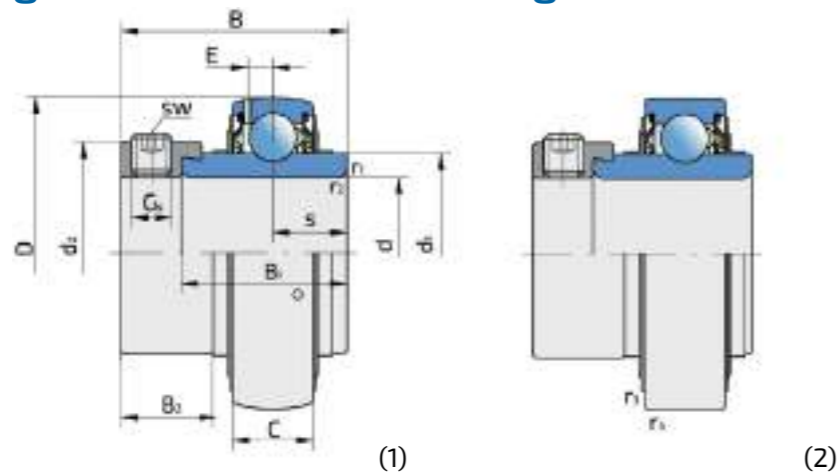

LY...  
LY...SH

Shaft		Dimensions (mm)									
d	D	B	C	s	d <sub>1</sub>	B <sub>1</sub>	d <sub>2</sub>	B <sub>2</sub>	E	Gs	sw
12	40	37.3	12	13.9	24.2	27.8	28.6	13.5	3.6	M6x0.75	3
15											
17											
20	47	43.7	14	17.1	28.2	34.1	33	13.5	4.3	M6x0.75	3
25	52	44.4	15	17.5	33.6	34.8	37.4	13.5	4.3	M6x0.75	3
	62	46.8	20	16.7	36.6	34.9	42.8	15.9	5	M8x1	4
30	62	48.4	18	18.3	39.7	36.5	44.2	16	5.1	M8x1	4
	72	50	23	17.5	44.6	36.5	50	17.5	5.6	M8x1	4
35	72	51.1	19	18.8	46.1	37.6	51.2	17.5	5.6	M10x1	5
	80	51.6	25	18.3	49.5	38.1	55	17.5	5.7	M8x1	4
40	80	56.3	22	21.4	56.6	42.8	63.6	18.3	6.1	M10x1	5
	90	57.1	29	19.8	62.1	42.9	70	20.6	7.1	M10x1	5
45	85	56.3	22	21.4	56.6	42.8	63.6	18.3	6.1	M10x1	5
	100	58.7	29	19.8	62.1	42.9	70	20.6	7.1	M10x1	5
50	90	62.7	22	24.6	62.5	49.2	67.6	18.3	6.4	M10x1	5
	110	66.6	32	24.6	68.7	49.2	76.2	22.2	7.9	M10x1	5
55	100	71.4	25	27.8	69.1	55.6	76.2	20.6	7	M10x1	5
	120	73	34	27.8	75.3	55.6	83	22.2	8.5	M10x1	5
60	110	77.8	26	31	75.5	62	84	22.3	7.7	M10x1	5
	130	68.4	33	23	81.7	52	89	23	9.0	M10x1	5
65	120	85.7	27	34.1	82.5	68.2	86	24	7.6	M10x1	5
	140	85.7	39	32.6	88.3	65.1	97	27	9.4	M12x1.5	6
70	125	85.7	28	34.1	87.1	68.2	92.9	23.8	8.1	M10x1	5
	150	92.1	41	34.2	94.9	68.3	102	30.2	10	M12x1.5	6
75	130	92.1	29	37.3	92.1	74.6	101.7	24	8.3	M10x1	5
80	140	100	30	40.4	97.4	80.8	110	26.2	8.2	M12x1.5	6
90	160	106.4	36	43.6	112.5	88.2	123.7	25.2	10	M12x1.5	6
	190	115.9	48	43.6	121	87.3	133	38.5	14.3	M20x1.5	
100	180	75	40	25.5	124.8	57.5	130	25.5	12	M12x1.5	6
	215	128.6	54	50	135	100	146	38.5	16.7	M20x1.5	
110	240	141.3	60	49.2	149	106.4	168	44.8	18	M20x1.5	
120	215	81	40	28.5	146.4	63.5	150	25.5	14	M12x1.5	6

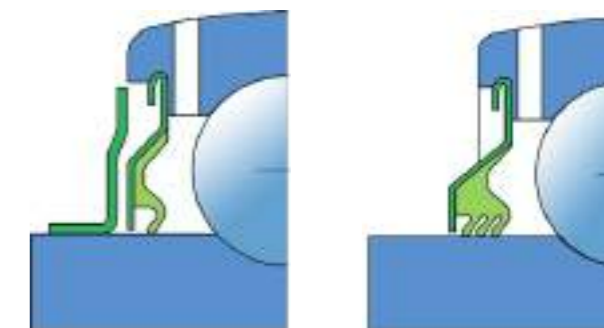

...2F

...2T

Load ratings (kN)					Mass	Designation	
r <sub>1,2</sub>	r <sub>3,4</sub>	C <sub>dyn</sub>	C <sub>0</sub>	P <sub>u</sub>	kg	1	2
0.3	0.6	9.56	4.75	0.200	0.162	LY 203/12 2F	LY 203/12 2F.SH
					0.143	LY 203/15 2F	LY 203/15 2F.SH
					0.128	LY 203 2F	LY 203 2F.SH
0.6	0.6	12.7	6.55	0.280	0.19	LY 204 2F	LY 204 2F.SH
0.6	0.6	14	7.8	0.335	0.23	LY 205 2F	LY 205 2F.SH
1.1	1.1	22.5	11.6	0.490	0.43	LY 305 2F	LY 305 2F.SH
0.6	0.6	19.5	11.2	0.475	0.37	LY 206 2F	LY 206 2F.SH
1.1	1.1	28.1	16	0.670	0.68	LY 306 2F	LY 306 2F.SH
1	1	25.5	15.3	0.655	0.57	LY 207 2F	LY 207 2F.SH
1.5	1.5	33.2	19	0.820	0.80	LY 307 2F	LY 307 2F.SH
1	1.5	30.7	19	0.800	0.80	LY 208 2F	LY 208 2F.SH
1.5	1.5	41	24	1.020	1.08	LY 308 2F	LY 308 2F.SH
1	1.5	33.2	21.6	0.915	0.76	LY 209 2F	LY 209 2F.SH
1.5	1.5	52.7	31.5	1.340	1.44	LY 309 2F	LY 309 2F.SH
1	1.5	35.1	23.2	0.980	0.91	LY 210 2F	LY 210 2F.SH
2	2	61.8	38	1.600	1.86	LY 310 2F	LY 310 2F.SH
1	2	43.6	29	1.25	1.20	LY 211 2F	LY 211 2F.SH
2	2	71.5	45	1.90	2.34	LY 311 2F	LY 311 2F.SH
1.5	2	52.7	36	1.53	1.67	LY 212 2F	LY 212 2F.SH
2.1	2.1	81	52	2.20	2.95	LY 312 2F	LY 312 2F.SH
1.5	2	57.2	40	1.70	2.30	LY 213 2F	LY 213 2F.SH
2.1	2.1	92.3	60	2.50	3.67	LY 313 2F	LY 313 2F.SH
1.5	2	62.4	44	1.86	2.50	LY 214 2F	LY 214 2F.SH
2.1	2.1	104	68	2.75	4.40	LY 314 2F	LY 314 2F.SH
1.5	2	66.3	49	2.04	2.90	LY 215 2F	LY 215 2F.SH
2	2.5	72.8	53	2.16	3.54	LY 216 2F	LY 216 2F.SH
2	2.5	95.6	72	2.70	5.11	LY 218 2F	LY 218 2F.SH
3	3	151	108	3.80	9.10	LY 318 2F	LY 318 2F.SH
2	2.5	124	93	3.35	4.35	LY 220 2F	LY 220 2F.SH
3	3	174	140	4.75	12.6	LY 320 2F	LY 320 2F.SH
3	3	203	180	5.70	17.2	LY 222 2F	LY 222 2F.SH
2	2.5	155	113	3.90	6.70	LY 224 2F	LY 224 2F.SH

## 4.5. Y-Ball Bearings with Integral Adapter Sleeve

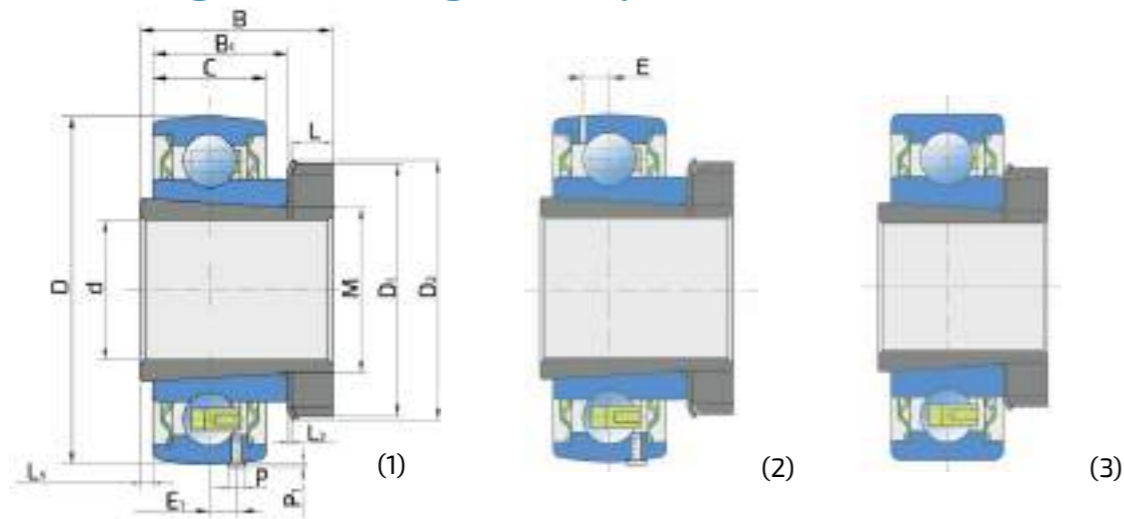

UH...

Shaft		Dimensions (mm)										
d	D	D <sub>1</sub>	D <sub>2</sub>	B	B <sub>1</sub>	C	L	L <sub>1</sub>	L <sub>2</sub>	E	E <sub>1</sub>	M
20	52	38	42.3	29	18	16	7	1	1.25	-	4.3	25x1.5
25	62	45	49	32	20	18	7	1	1.25	-	5	30x1.5
30	72	52	57	35	22	19	8	1	1.25	-	5.7	35x1.5
35	80	58	62	36	23	21	9	1	1.25	-	6.5	35x1.5
40	85	65	69	39	23	21	10	1	1.25	-	6.5	40x1.5
30	85	52	57	35	23	23	8	1	1.25	-	-	35x1.5
35	85	58	62	36	23	23	9	1	1.25	-	-	40x1.5
40	85	65	69	39	23	23	10	1	1.25	-	-	45x1.5
40	85	65	69	39	23	21	10	1	1.25	6.5	6.5	45x1.5
50	100	75	81	45	25	25	11	1	1.25	7	7	50x2
70	150	105	112	70	45	39	15	1	1.75	12	12	80x2

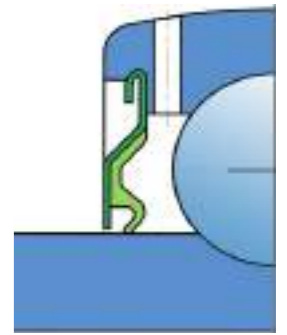

...25

P	P <sub>1</sub>	Load ratings (kN)			Mass kg	Designation	Fig.
		C <sub>dyn</sub>	C <sub>0</sub>	P <sub>u</sub>			
3	2	14	7.8	0.335	0.196	UH 205/20 2S.H.T	1
3	2	19.5	11.2	0.475	0.337	UH 206/25 2S.H.T	1
3	2	25.5	15.3	0.655	0.467	UH 207/30 2S.H.T	1
3	2	30.7	19	0.800	0.600	UH 208/35 2S.H.T	1
3	2	33.2	21.6	0.915	0.643	UH 209/40 2S.H.T	1
-	-	33.2	21.6	0.915	0.737	UH 209/30 2S.SH	3
-	-	33.2	21.6	0.915	0.700	UH 209/35 2S.SH	3
-	-	33.2	21.6	0.915	0.727	UH 209/40 2S.SH	3
3	2	33.2	21.6	0.915	0.643	UH 209/40 2S.T	2
3	2	43.6	29	1.25	1.002	UH 211/50 2S.T	2
5	2.8	85	65	2.5	3.87	UH 217/70 2S.T	2

#### 4.6. Y-Ball Bearings with Extended Standard Inner Ring

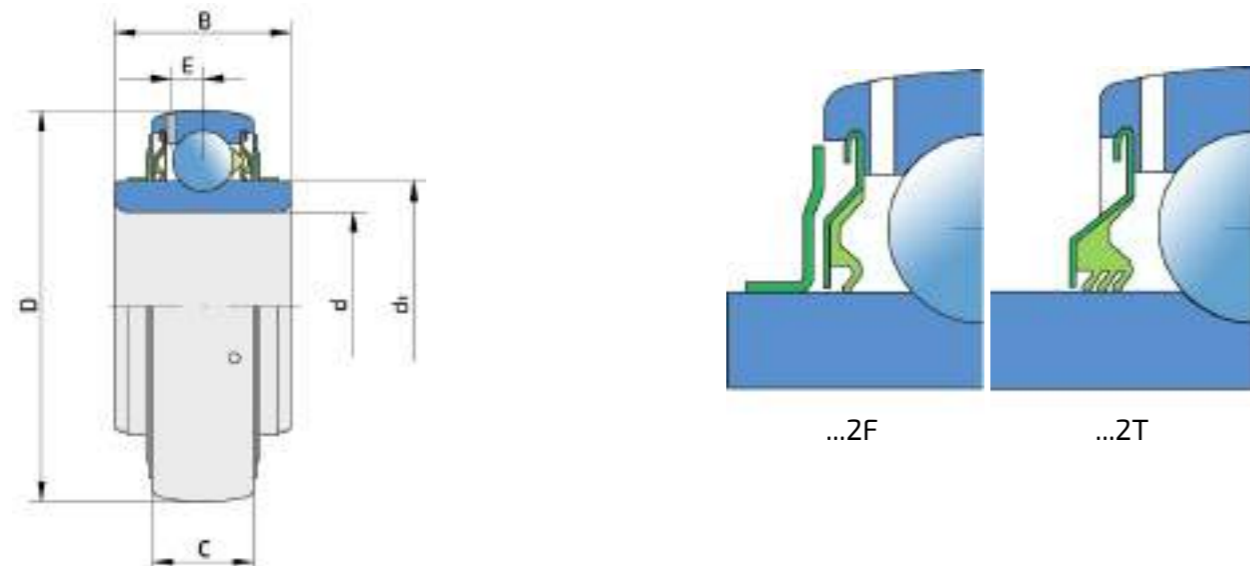

LS...

Shaft d	Dimensions (mm)					Load rating (kN)			Mass kg	Designations
	D	B	C	d <sub>1</sub>	E	C <sub>dyn</sub>	C <sub>o</sub>	P <sub>u</sub>		
25	52	24	15	33.6	4.3	14	7.8	0.335	0.14	LS 205 2F
30	62	28	18	39.7	5.1	19.5	11.2	0.475	0.23	LS 206 2F
35	72	30.5	19	46.1	5.6	25.5	15.3	0.655	0.31	LS 207 2F
40	80	33.9	21	51.8	6.1	30.7	19	0.800	0.43	LS 208 2F
45	85	35	22	56.6	6.1	33.2	21.6	0.915	0.53	LS 209 2F
50	90	37	22	62.5	6.4	35.1	23.2	0.980	0.6	LS 210 2F
55	100	40	25	69.1	7	43.6	29	1.25	0.79	LS 211 2F

#### 4.7. Y-Ball Bearings with Drive Slot in Inner Ring

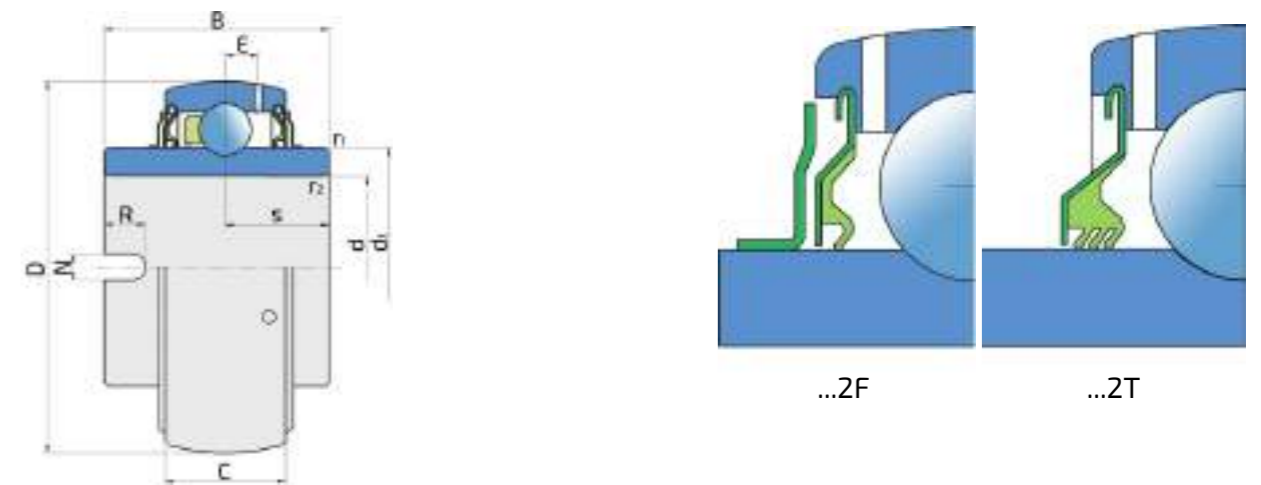

LN...

Shaft d	Dimensions (mm)							Load rating (kN)			Mass kg	Designations
	D	B	C	d <sub>1</sub>	N	R	E	C <sub>dyn</sub>	C <sub>o</sub>	P <sub>u</sub>		
20	47	34.1	14	28.2	7	7	4.3	12.7	6.55	0.280	0.16	LN 204 2F
30	62	36.5	18	39.7	8	7	5.1	19.5	11.2	0.475	0.30	LN 206 2F
35	72	37.7	19	46.1	8	7	5.6	25.5	15.3	0.655	0.49	LN 207 2F

\* All bearings are also available with 2T sealing.

\* All bearings are also available with 2T sealing.

#### 4.8. Y-Ball Bearings with Standard Inner Ring

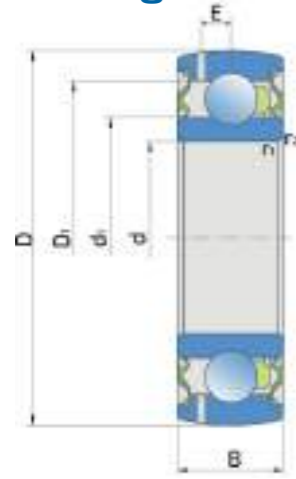

...2S

US...

Shaft d	Dimensions (mm)						Load rating (kN)			Mass kg	Designations
	D	B	d <sub>1</sub>	D <sub>1</sub>	E	r <sub>1.2</sub>	C <sub>dyn</sub>	C <sub>o</sub>	P <sub>u</sub>		
17	40	12	24.2	32.6	3.6	0.6	7.35	4.75	0.140	0.064	US 203 2S
	47	14	26.5	37.6	4.3	0.7	13.5	6.55	0.275	0.14	US 303 2S
20	47	14	28.2	38.6	4.3	1	12.8	6.6	0.196	0.094	US 204 2S
	52	15	33.6	44	4.3	1	14	7.80	0.232	0.116	US 205 2S
25	62	17	36.6	50.9	5.6	1.1	22.5	11.6	0.49	0.20	US 305 2S
	62	16	39.7	51.6	5.1	1	19.5	11.3	0.335	0.18	US 206 2S
30	72	19	44.6	59.2	6.1	1.1	28.1	16	0.67	0.30	US 306 2S
	72	17	46.1	60.5	5.6	1.1	25.5	15.3	0.455	0.28	US 207 2S
35	80	21	49.5	66.1	7	1.5	33.2	19	0.82	0.40	US 307 2S
	80	18	52.0	67.3	6.1	1.1	32.5	19.8	0.560	0.37	US 208 2S
40	90	23	56.1	74.7	7.6	1.5	41	24	1.02	0.55	US 308 2S
	85	19	56.6	72.6	6.1	1.1	32.5	20.4	0.640	0.40	US 209 2S
45	100	25	62.1	83.7	7.7	1.5	52.7	31.5	1.34	0.73	US 309 2S
	90	20	62.5	78.2	6.4	1.1	35	23.2	0.695	0.45	US 210 2S
50	110	27	68.7	92.6	7.7	2	61.8	38	1.6	0.95	US 310 2S
	100	21	69.1	85.9	7	1.5	43.5	29.0	0.865	0.60	US 211 2S
60	110	22	75.5	95	7.7	1.5	52	36.0	1.060	0.77	US 212 2S
65	120	23	82.5	102.46	7.6	1.5	57	40	1.73	0.94	US 213 2S

#### 4.9. Y-Ball Bearings with Tapered Bore Y-Ball Bearings with Adapter Sleeve

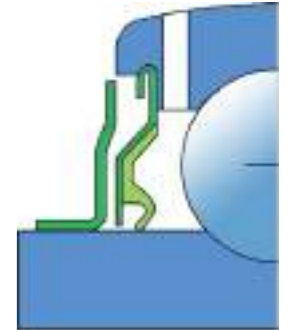
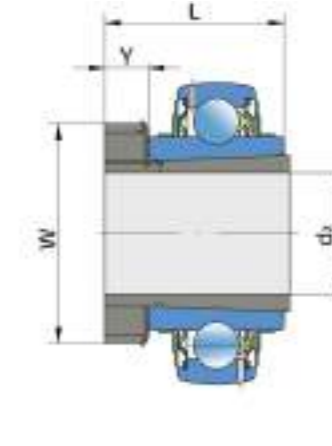
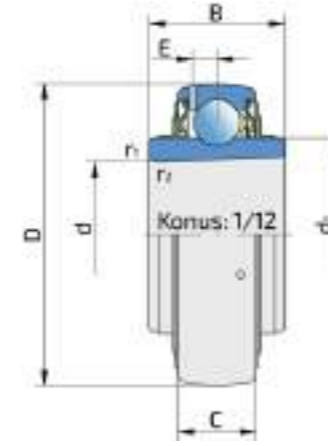

...2F

LK...  
LK...+H...

Shaft d <sub>2</sub>	Dimensions (mm)									Load ratings (kN)			Mass kg	Designation 1, 2
	d	D	L	B	C	d <sub>1</sub>	W	Y	E	C <sub>dyn</sub>	C <sub>o</sub>	P <sub>u</sub>		
20	25	52	-	24	15	33.6	-	-	4.3	14	7.8	0.232	0.13	LK 205 2F
							38	8					0.22	LK 205 2F+H 2305
25	30	62	-	28	18	39.7	-	-	5.1	19.5	11.3	0.335	0.22	LK 206 2F
							38	8					0.33	LK 206 2F+H 2306
30	35	72	-	30.5	19	46.1	-	-	5.6	25.5	15.3	0.445	0.29	LK 207 2F
							43	9					0.47	LK 207 2F+H 2307
35	40	80	-	33.9	21	52	-	-	6.1	32.5	19.8	0.560	0.41	LK 208 2F
							46	10					0.63	LK 208 2F+H 2308
40	45	85	-	35	22	56.6	-	-	6.1	32.5	20.4	0.640	0.47	LK 209 2F
							50	11					0.73	LK 209 2F+H 2309
45	50	90	-	37	22	62.5	-	-	6.4	35	23.2	0.695	0.51	LK 210 2F
							55	12					0.86	LK 210 2F+H 2310
50	55	100	-	40	25	69.1	-	-	7	43.5	29	0.865	0.75	LK 211 2F
							59	12					1.10	LK 211 2F+H 2311
55	60	110	-	42.5	26	75.5	-	-	7.7	52	36	1.060	1.05	LK 212 2F
							62	13					1.40	LK 212 2F+H 2312
60	65	120	-	38	27	82.5	-	-	7.6	57	40	1.180	1.30	LK 213 2F
							65	14					1.70	LK 213 2F+H 2313
65	75	130	-	41	29	92.1	-	-	8.3	62	44.5	1.44	1.54	LK 215 2F
							73	15					2.59	LK 215 2F+H 2315
70	80	140	-	44	30	97.4	-	-	8.2	72	54	1.53	1.99	LK 216 2F
							78	17					3.27	LK 216 2F+H 2316
75	85	150	-	46	34	105	-	-	8.2	85	65	1.72	2.47	LK 217 2F
							82	18					3.92	LK 217 2F+H 2317
80	90	160	-	58	36	112	-	-	10	102	79	1.96	2.99	LK 218 2F
							86	18					4.68	LK 218 2F+H 2318

## 4.10. Y-Ball Bearings with Tapered Bore

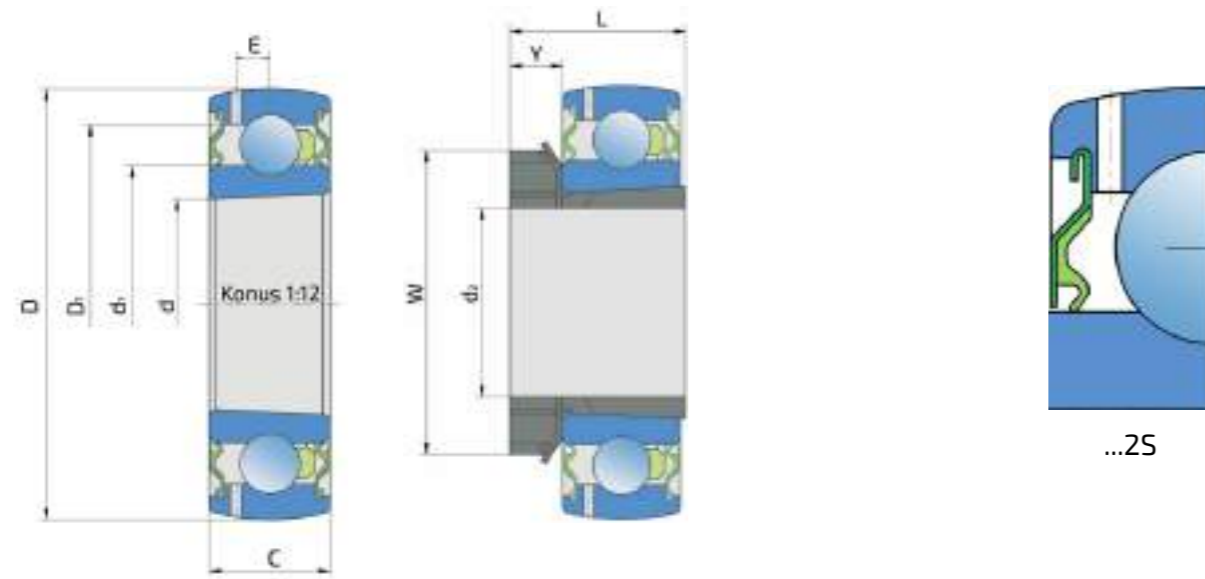

UK...

Shaft	Dimensions (mm)						Load rating (kN)			Mass	Designation				
$d_2$	d	D	L	B	C	$d_1$	$D_1$	W	Y	E		$C_{dyn}$	$C_o$	$P_u$	kg
20	25	52	-	15	15	33.6	44	-	-	4.3	14.0	7.80	0.232	0.14	UK 205 2S
			26	38	8	UK 205 2S+H 205									
25	30	62	-	16	16	39.7	51.6	-	-	5.1	19.5	11.3	0.335	0.18	UK 206 2S
			27	45	8	UK 206 2S+H 206									
30	35	72	-	17	17	46.1	60.5	-	-	5.6	25.5	15.3	0.445	0.28	UK 207 2S
			29	52	9	UK 207 2S+H 207									
35	40	80	-	18	18	52	67.3	-	-	6.1	32.5	19.8	0.560	0.36	UK 208 2S
			31	58	10	UK 208 2S+H 208									
40	45	85	-	19	19	56.6	72.6	-	-	6.1	32.5	20.4	0.640	0.39	UK 209 2S
			33	65	11	UK 209 2S+H 209									
45	50	90	-	20	20	62.5	78.2	-	-	6.4	35.0	23.2	0.695	0.44	UK 210 2S
			55	70	12	UK 210 2S+H 210									
50	55	100	-	21	21	69.1	85.9	-	-	7	43.5	29.0	0.865	0.59	UK 211 2S
			59	75	12	UK 211 2S+H 211									
55	60	110	-	22	22	75.5	95	-	-	7.7	52.0	36.0	1.060	0.75	UK 212 2S
			62	80	13	UK 212 2S+H 212									

## 4.11. Y-Ball Bearings with Standard Inner Ring

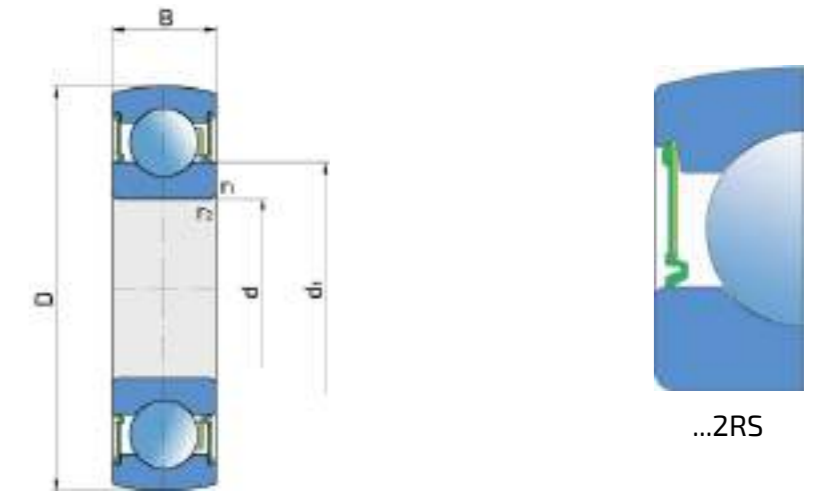

172...

Shaft	Dimensions (mm)				Load ratings (kN)			Mass	Designation
d	D	B	$d_1$	$r_{1.2}$	$C_{dyn}$	$C_o$	$P_u$	kg	
15	35	11	21.5	0.6	7.80	3.75	0.16	0.04	1726202 2RS1
17	40	12	24.2	0.6	9.50	4.75	0.20	0.06	1726203 2RS1
		14	26.5	0.7	13.5	6.55	0.29	0.14	1726303 2RS1
20	47	14	28.2	1	12.7	6.55	0.28	0.10	1726204 2RS1
25	52	15	33.6	1	14	7.80	0.34	0.11	1726205 2RS1
		17	36.6	1.1	22.5	11.6	0.49	0.20	1726305 2RS1
30	62	16	39.7	1	19.5	11.2	0.48	0.18	1726206 2RS1
		19	44.6	1.1	28.1	16	0.67	0.30	1726306 2RS1
35	72	17	46.1	1	25.5	15.3	0.66	0.25	1726207 2RS1
		21	49.5	1.5	33.2	19	0.82	0.40	1726307 2RS1
40	80	18	52	1.1	30.7	19	0.80	0.32	1726208 2RS1
		23	56.1	1.5	41	24	1.02	0.55	1726308 2RS1
45	85	19	56.6	1.1	32.5	20.4	0.92	0.37	1726209 2RS1
		25	62.1	1.5	52.7	31.5	1.34	0.73	1726309 2RS1
50	90	20	62.5	1.1	35.1	23.2	0.98	0.41	1726210 2RS1
		27	68.7	2	61.8	38	1.60	0.95	1726310 2RS1
55	100	21	69.1	1.5	43.6	29	1.25	0.56	1726211 2RS1
60	110	22	75.5	1.5	52	36	1.40	0.75	1726212 2RS1
65	120	23	82.5	1.5	57	40	1.73	0.94	1726213 2RS1

# Angular Contact Ball Bearings



## 5.1. Angular Contact Ball Bearing - Double Row

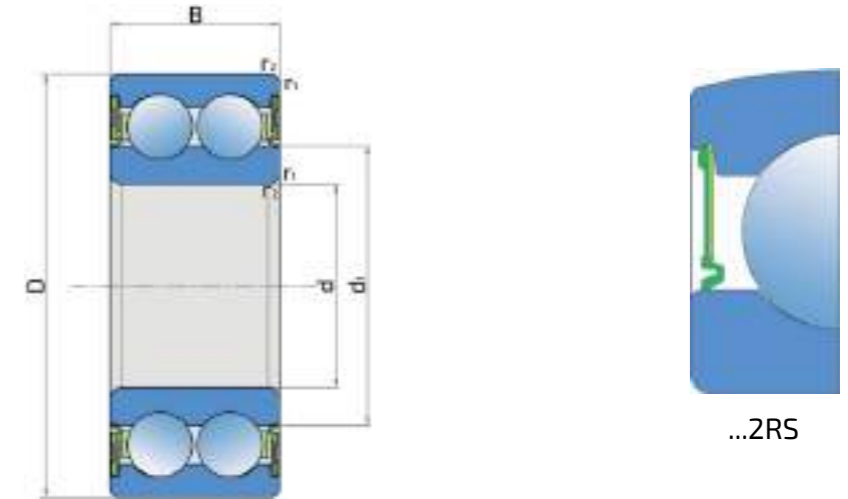

32...  
33...

Shaft d	Dimensions (mm)			Load ratings (kN)				Mass kg	Designation
	D	B	d <sub>1</sub>	r <sub>1,2</sub>	C <sub>dyn</sub>	C <sub>o</sub>	P <sub>u</sub>		
20	47	20.6	27.7	1	20	12	0.51	0.16	3204 B.2RS1
25	52	20.6	32.7	1	21.6	14.3	0.6	0.18	3205 B.2RS1
30	62	23.8	38.7	1	30	20.4	0.87	0.29	3206 B.2RS1
35	80	34.9	44.6	1.5	52	35.5	1.5	0.71	3307 B.2RS1



# Y-Bearing Units Data

6.1. Housing "S" .....	50
6.2. Housing "V" .....	52
6.3. Housing "U" .....	54
6.4. Housing "F" .....	56
6.5. Housing "N" .....	58
6.6. Housing "G" .....	60
6.7. Housings "T" .....	62
6.8. Housing "C" .....	64
6.9. Housing "D" .....	66
6.10. Housing "P" .....	67



## 6.1. Y-Bearing Plummer Block Units with Grey Cast Iron Housing "S"

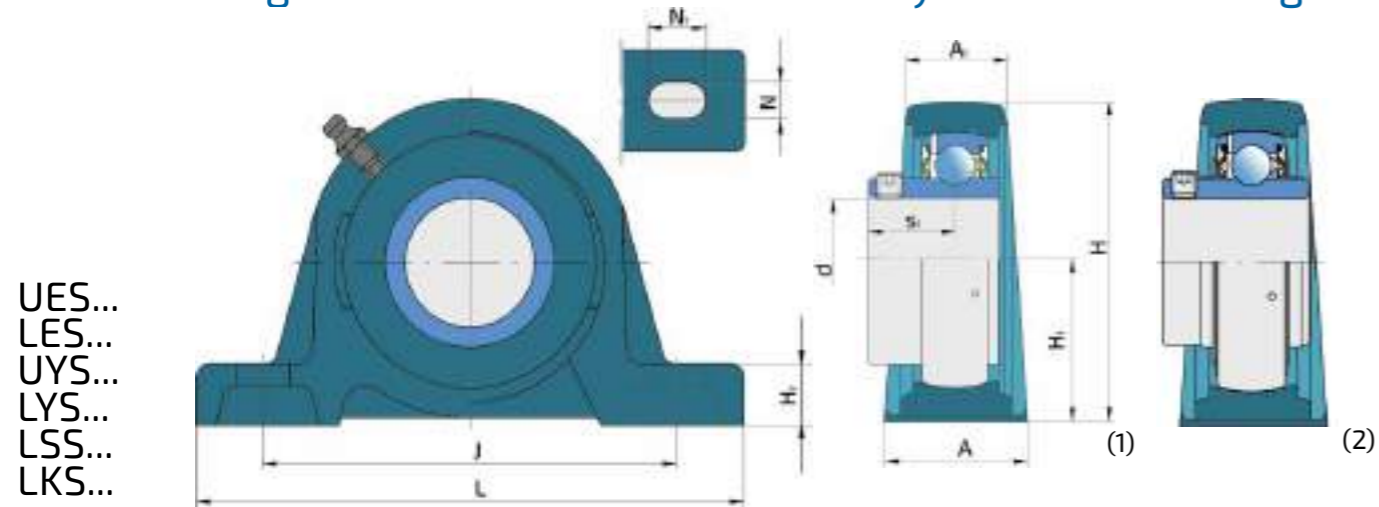

UES...  
LES...  
UYS...  
LYS...  
LSS...  
LKS...

Shaft d	Dimensions (mm)												fig.	Mass kg	Designation
	A	A <sub>1</sub>	H	H <sub>1</sub>	H <sub>2</sub>	J <sub>min.</sub>	J <sub>max.</sub>	L	N	N <sub>1</sub>	s <sub>1</sub>				
17	32	18	56.2	30.2	14	88	106	127	11.5	20.5	15.9	1	0.48	UES 203 2S	
												2	0.50	LES 203 2F	
												3	0.52	UYS 203 2S	
												4	0.54	LYS 203 2F	
20	34	23	63.8	33.3	14	89	104.5	127	13	20.7	18.3	1	0.55	UES 204 2S	
												2	0.57	LES 204 2F	
												3	0.59	UYS 204 2S	
												4	0.62	LYS 204 2F	
25	38	24	69.5	36.5	16	94	111	140	13	21.5	20	6	0.77	LKS 205 2F + H2305	
												1	0.70	UES 205 2S	
												2	0.73	LES 205 2F	
												3	0.73	UYS 205 2S	
30	42	27	81.4	42.9	16	111	125	165	17	24	22	6	1.15	LKS 206 2F + H2306	
												1	1.06	UES 206 2S	
												2	1.12	LES 206 2F	
												3	1.12	UYS 206 2S	
35	46	28	92.1	47.6	17	122	136	167	17	24	24.3	6	1.55	LKS 207 2F + H2307	
												1	1.46	UES 207 2S	
												2	1.53	LES 207 2F	
												3	1.58	UYS 207 2S	
40	49	31	98.2	49.2	18	128	145	184	17	25.5	27	6	1.90	LKS 208 2F + H2308	
												1	1.85	UES 208 2S	
												2	1.96	LES 208 2F	
												3	1.99	UYS 208 2S	
45	52	36	107	54	20	136	151	190	17	23.5	28.5	6	2.35	LKS 209 2F + H2309	

\* All bearing units are available from Ductile Cast Iron.

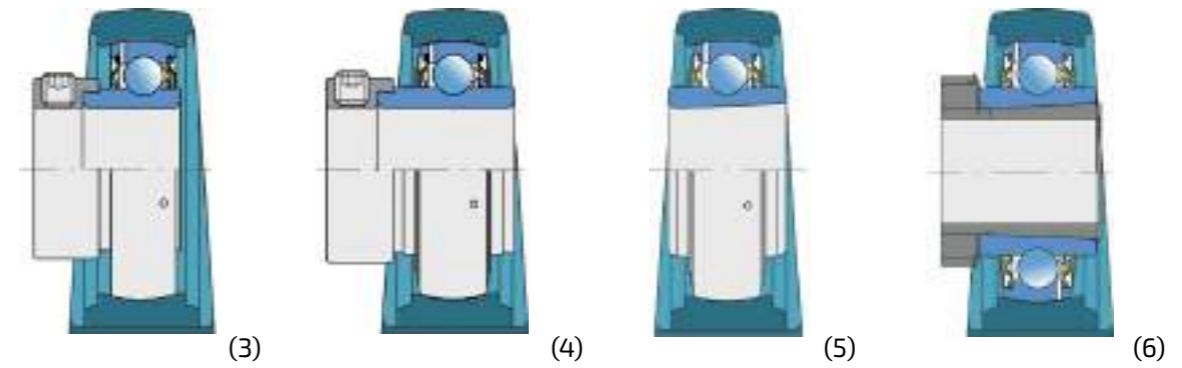

Shaft d	Dimensions (mm)												fig.	Mass kg	Designation
	A	A <sub>1</sub>	H	H <sub>1</sub>	H <sub>2</sub>	J <sub>min.</sub>	J <sub>max.</sub>	L	N	N <sub>1</sub>	s <sub>1</sub>				
45	52	36	107	54	20	136	151	190	17	23.5	25.8	1	2.23	UES 209 2S	
												2	2.34	LES 209 2F	
												3	2.34	UYS 209 2S	
												4	2.46	LYS 209 2F	
50	58	38	113.2	57.2	22	151	164	206	20	26.5	30.5	6	2.85	LKS 210 2F + H2310	
												1	2.59	UES 210 2S	
												2	2.74	LES 210 2F	
												3	2.73	UYS 210 2S	
55	60	40	125.5	63.5	24	163	180	219	20	27.5	32.5	6	3.75	LKS 211 2F + H2311	
												2	3.62	LES 211 2F	
												3	3.59	UYS 211 2S	
												4	3.80	LYS 211 2F	
60	65	47	136.8	69.8	26.5	179	198	241	20	29.5	34.3	6	4.55	LKS 212 2F + H2312	
												2	4.62	LES 212 2F	
												3	4.19	UYS 212 2S	
												4	4.82	LYS 212 2F	
65	70	49	150	76.2	27	193	213	265	25	35	35.8	6	5.70	LKS 213 2F + H2313	
												2	6.02	LES 213 2F	
												4	6.55	LYS 213 2F	
												6	7.55	LKS 215 2F + H2315	
70	72	46	155	79.4	27	205	215	266	25	30	39.7	2	6.60	LES 214 2F	
												4	7.10	LYS 214 2F	
												6	9.50	LKS 216 2F + H2316	
												2	7.80	LES 215 2F	
75	74	54	165	82.5	28	209	225	275	25	33	46.3	2	7.80	LES 215 2F	
												4	8.40	LYS 215 2F	
												2	9.20	LES 216 2F	
												4	10.0	LYS 216 2F	
80	78	50	175	88.9	30	222	242	292	25	35	47.6	2	9.20	LES 216 2F	
												4	10.0	LYS 216 2F	
												6	13.7	LKS 218 2F + H2318	
												2	13.7	LES 218 2F	
85	82	52	181	91.5	31	227	247	297	25	35	48.9	6	13.7	LKS 218 2F + H2318	
												2	14.6	LYS 218 2F	
												4	17.8	LES 220 2F	
												4	17.4	LYS 220 2F	

## 6.2. Y-Bearing Plummer Block Units with Grey Cast Iron Housing "V"

UEV...  
LEV...  
UYV...  
LYV...  
LSV...  
LKV...

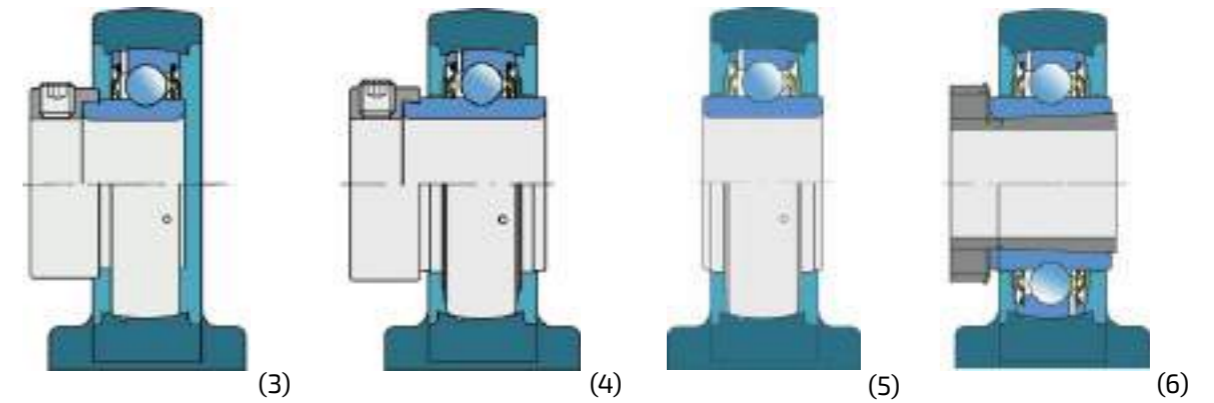
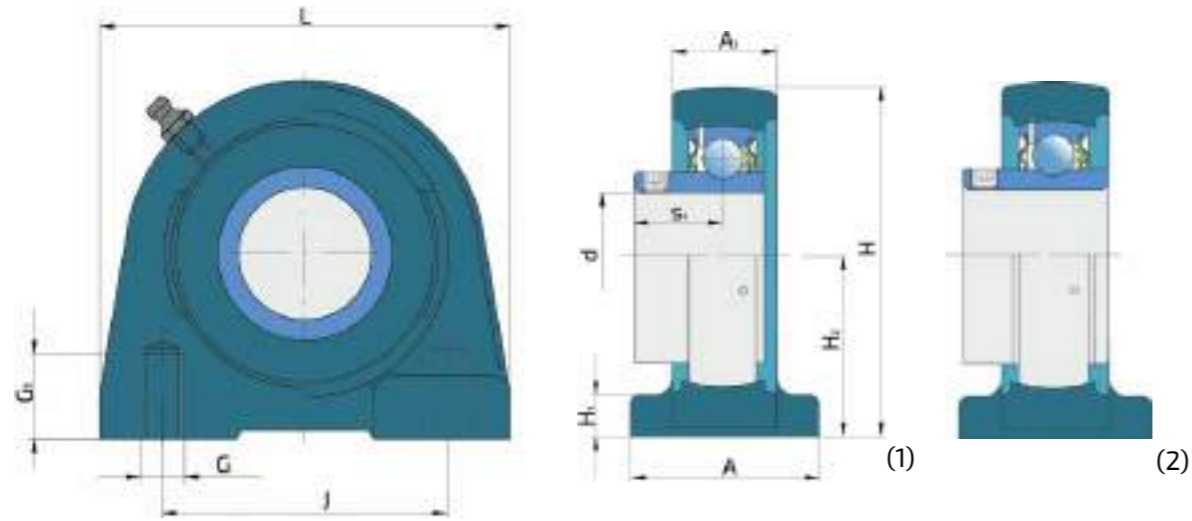

Shaft d	Dimensions (mm)											fig.	Mass kg	Designation
	L	A	J	H	G	G <sub>1</sub>	H <sub>1</sub>	H <sub>2</sub>	A <sub>1</sub>	s <sub>1</sub>				
20	76	38	52	62	M10	12	8	30.2	24	18.3	1	0.52	UEV 204 2S	
											2	0.54	LEV 204 2F	
											3	0.56	UYV 204 2S	
											4	0.59	LYV 204 2F	
											6	0.74	LKV 205 2F + H2305	
											84	38	56	72
25	84	38	56	72	M10	15	10	36.5	25	19.5	1	0.65	UEV 205 2S	
											2	0.68	LEV 205 2F	
											3	0.68	UYV 205 2S	
											4	0.73	LYV 205 2F	
											5	0.65	LSV 205 2F	
											94	48	66	84
30	94	48	66	84	M14	18	10	42.9	28.5	21	1	0.97	UEV 206 2S	
											2	1.03	LEV 206 2F	
											3	1.03	UYV 206 2S	
											4	1.10	LYV 206 2F	
											5	0.97	LSV 206 2F	
											110	48	80	95
35	110	48	80	95	M14	20	12	47.6	30.5	23.3	1	1.37	UEV 207 2S	
											2	1.44	LEV 207 2F	
											3	1.49	UYV 207 2S	
											4	1.57	LYV 207 2F	
											5	1.38	LSV 207 2F	
											116	54	84	100

Shaft d	Dimensions (mm)											fig.	Mass kg	Designation
	L	A	J	H	G	G <sub>1</sub>	H <sub>1</sub>	H <sub>2</sub>	A <sub>1</sub>	s <sub>1</sub>				
40	116	54	84	49.2	M14	20	12	100	31.5	25.3	1	0.56	UEV 208 2S	
											2	1.67	LEV 208 2F	
											3	1.70	UYV 208 2S	
											4	1.79	LYV 208 2F	
											5	1.59	LSV 208 2F	
											120	54	90	54.2
45	120	54	90	54.2	M14	25	12	108	33.5	25.8	1	1.80	UEV 209 2S	
											2	1.91	LEV 209 2F	
											3	1.89	UYV 209 2S	
											4	1.91	LYV 209 2F	
											5	1.82	LSV 209 2F	
											130	60	94	57.2
50	130	60	94	57.2	M16	25	14	116	35.5	27.6	1	2.18	UEV 210 2S	
											2	2.33	LEV 210 2F	
											3	2.32	UYV 210 2S	
											4	2.51	LYV 210 2F	
											5	2.24	LSV 210 2F	

\* All bearing units are available from Ductile Cast Iron.

### 6.3. Y-Bearing Plummer Block Units with Grey Cast Iron Housing "U"

UEU...  
LEU...  
UYU...  
LYU...  
LSU...  
LKU...

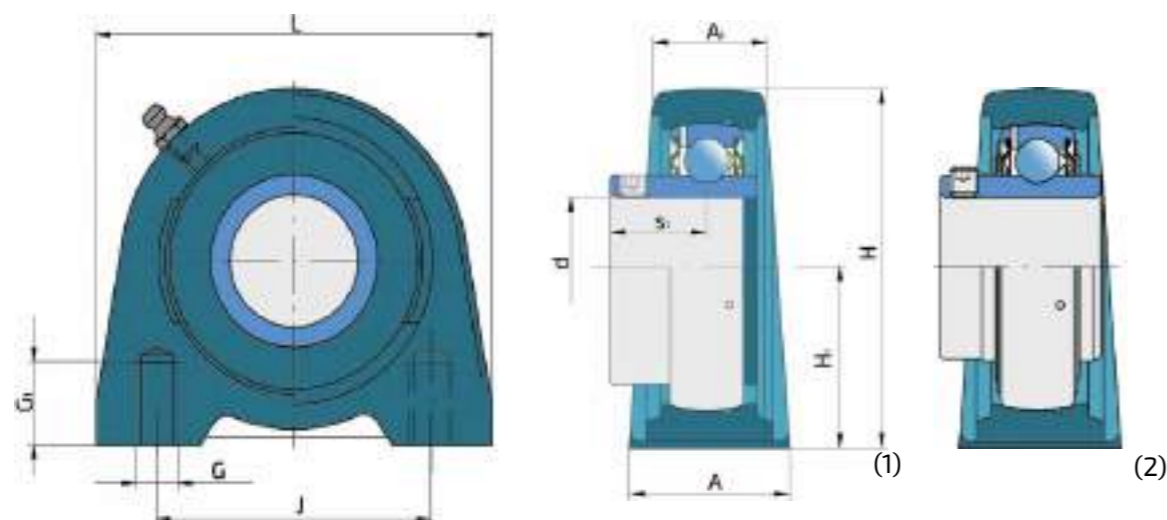

Shaft d	Dimensions (mm)										Mass kg	Designation
	L	A	A <sub>1</sub>	J	G	G <sub>1</sub>	H	H <sub>1</sub>	s <sub>1</sub>	fig.		
20	65	32	21	50.8	M8	14	63.8	33.3	18.3	1	0.52	UEU 204 2S
										2	0.54	LEU 204 2F
										3	0.56	UYU 204 2S
										4	0.59	LYU 204 2F
										6	0.74	LKU 204 2F + H2305
										70	36	22
25	70	36	22	50.8	M10	15	69.5	36.5	19.5	1	0.65	UEU 205 2S
										2	0.68	LEU 205 2F
										3	0.68	UYU 205 2S
										4	0.73	LYU 205 2F
										5	0.65	LSU 205 2F
										12	0.65	LSU 205 2F
30	98	40	25	76.2	M10	15	81.4	42.9	22	7	1.13	LKU 205 2F + H2306
										21	0.97	UEU 206 2S
										22.2	1.03	LEU 206 2F
										26.7	1.03	UYU 206 2S
										30.1	1.10	LYU 206 2F
										14	0.97	LSU 206 2F
35	103	45	27	82.6	M10	15	92.1	47.6	24.3	6	1.53	LKU 207 2F + H2307
										23.3	1.37	UEU 207 2S
										25.5	1.44	LEU 207 2F
										29.4	1.49	UYU 207 2S
										32.3	1.57	LYU 207 2F
										15.2	1.38	LSU 207 2F
40	116	48	30	88.9	M12	20	98.2	49.2	27	6	1.76	LKU 208 2F + H2308

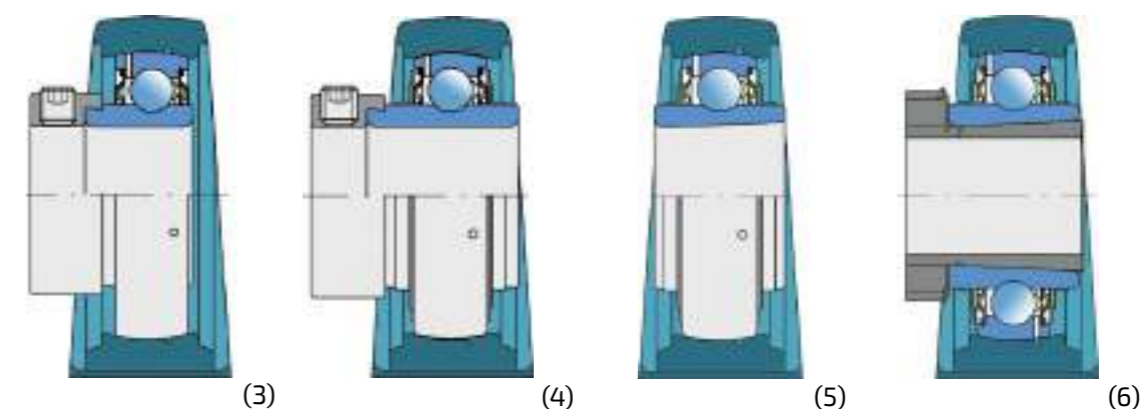

Shaft d	Dimensions (mm)										Mass kg	Designation
	L	A	A <sub>1</sub>	J	G	G <sub>1</sub>	H	H <sub>1</sub>	s <sub>1</sub>	fig.		
40	116	48	30	88.9	M12	20	98.2	49.2	25.3	1	1.56	UEU 208 2S
										2	1.67	LEU 208 2F
										3	1.70	UYU 208 2S
										4	1.79	LYU 208 2F
										5	1.59	LSU 208 2F
										17	1.59	LSU 208 2F
45	120	48	32	95.3	M12	22	106.5	54	28.5	6	2.04	LKU 209 2F + H2309
										25.8	1.80	UEU 209 2S
										30.2	1.91	LEU 209 2F
										32.7	1.89	UYU 209 2S
										34.9	1.91	LYU 209 2F
										17.5	1.82	LSU 209 2F
50	135	54	34	101.6	M16	25.5	113.2	57.2	30.5	6	2.53	LKU 210 2F + H2310
										27.6	2.18	UEU 210 2S
										32.6	2.33	LEU 210 2F
										32.7	2.32	UYU 210 2S
										38.1	2.51	LYU 210 2F
										20	2.24	LSU 210 2F

\* All bearing units are available from Ductile Cast Iron.

## 6.4. Y-Bearing Flanged Units with Square Grey Cast Iron Housing "F"

UEF...  
LEF...  
UYF...  
LYF...  
LSF...  
LKF...



Shaft d	Dimensions (mm)						fig.	Mass kg	Designation
	A	A <sub>1</sub>	A <sub>2</sub>	J	L	N			
17	32.9	26	11	54	76	11.5	1	0.42	UEF 203 2S
	32.9						2	0.44	LEF 203 2F
	39.1						3	0.46	UYF 203 2S
	40.4						4	0.48	LYF 203 2F
20	33.3	25.5	11	64	86	12	1	0.52	UEF 204 2S
	33.3						2	0.54	LEF 204 2F
	38.5						3	0.56	UYF 204 2S
	41.6						4	0.59	LYF 204 2F
25	39	27	12	70	95	12	6	0.73	LKF 205 2F + H2305
	35.5	27	12	70	95	12	1	0.70	UEF 205 2S
	35.8						2	0.73	LEF 205 2F
	39.5						3	0.73	UYF 205 2S
	42.9						4	0.78	LYF 205 2F
	28						5	0.70	LSF 205 2F
30	40	31	13	83	108	12	6	1.05	LKF 206 2F + H2306
	39	31	13	83	108	12	1	0.94	UEF 206 2S
	40.2						2	1.00	LEF 206 2F
	44.7						3	1.00	UYF 206 2S
	48.1						4	1.07	LYF 206 2F
	32						5	0.94	LSF 206 2F
35	43.3	34	13	92	118	14	6	1.35	LKF 207 2F + H2307
	42.3	34	13	92	118	14	1	1.27	UEF 207 2S
	44.5						2	1.34	LEF 207 2F
	48.4						3	1.39	UYF 207 2S
	51.3						4	1.47	LYF 207 2F
	34.3						5	1.28	LSF 207 2F
40	48	36	14	102	130	16	6	1.75	LKF 208 2F + H2308
	46.3	36	14	102	130	16	1	1.68	UEF 208 2S
	51.2						2	1.79	LEF 208 2F
	53.7						3	1.82	UYF 208 2S
	52.2						4	1.91	LYF 208 2F
	38						5	1.71	LSF 208 2F
40	50.5	38	16	105	137	16	6	2.10	LKF 209 2F + H2309

\* All bearing units are available from Ductile Cast Iron.

Shaft d	Dimensions (mm)						fig.	Mass kg	Designation
	A	A <sub>1</sub>	A <sub>2</sub>	J	L	N			
45	47.8	38	16	105	137	16	1	2.08	UEF 209 2S
	52.2						2	2.19	LEF 209 2F
	54.7						3	2.19	UYF 209 2S
	56.9						4	2.31	LYF 209 2F
	39.5						5	2.10	LSF 209 2F
	52.5	40	15	111	143	16	6	2.80	LKF 210 2F + H2310
50	49.6	40	15	111	143	16	1	2.43	UEF 210 2F
	54.6						2	2.58	LEF 210 2F
	54.7						3	2.57	UYF 210 2S
	60.1						4	2.76	LYF 210 2F
	40.5						5	2.49	LSF 210 2F
	57.5	43	17	130	162	19	6	3.60	LKF 211 2F + H2311
55	58.4	43	17	130	162	19	2	3.42	LEF 211 2F
	60.9						3	3.39	UYF 211 2S
	68.6						4	3.60	LYF 211 2F
	45						5	3.39	LSF 211 2F
	63.3	48	18	143	175	19	6	4.60	LKF 212 2F + H2312
	68.7	48	18	143	175	19	2	4.27	LEF 212 2F
60	69.3						3	3.84	UYF 212 2F
	75.8						4	4.47	LYF 212 2F
	65.8	50	22	149	187	19	6	6.00	LKF 213 2F + H2313
	72.9	50	22	149	187	19	2	5.57	LEF 213 2F
	81.6						4	6.10	LYF 213 2F
	73.7	50.3	21.3	152	193	19	6	7.00	LKF 215 2F + H2315
70	70.7	50.3	21.3	152	193	19	2	6.20	LEF 214 2F
	82.6						4	6.70	LYF 214 2F
	76.5	53.6	22.1	159	200	19	6	7.80	LKF 216 2F + H2316
	80.3	53.6	22.1	159	200	19	2	7.00	LEF 215 2F
	88.8						4	7.60	LYF 215 2S
	81.6	54.5	22	165	208	23	2	7.50	LEF 216 2F
80	93.6						4	8.34	LYF 216 2F
	88.6	63.4	23.4	187	235	23	6	11.6	LKF 218 2F + H2318
	94.0	63.4	23.4	187	235	23	2	11.6	LEF 218 2F
	102.8						4	12.5	LYF 218 2F
	107.5	70	25	210	265	27	2	13.9	LEF 220 2F
	93.6						4	13.5	LYF 220 2F

## 6.5. Y-Bearing Flanged Units with Oval Grey Cast Iron Housing "N"

UEN...  
LEN...  
UYN...  
LYN...  
LSN...  
LKN...

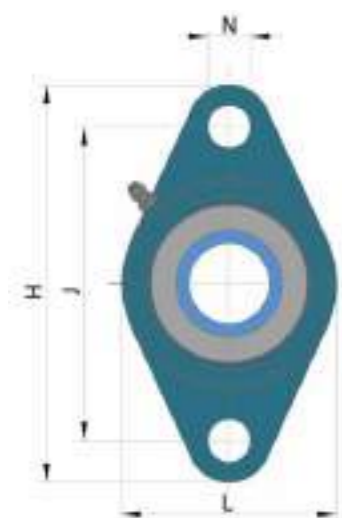

(1)



(2)



(3)



(4)



(5)



(6)

Shaft d	Dimensions (mm)							fig.	Mass kg	Designation
	A	A <sub>1</sub>	A <sub>2</sub>	H	J	L	N			
17	32.9	26	11	98.5	76.5	57	11.5	1	0.37	UEN 203 2S
	32.9							2	0.39	LEN 203 2F
	39.1							3	0.41	UYN 203 2S
	40.4							4	0.43	LYN 203 2F
20	33.3	25.5	11	112	90	60	12	1	0.41	UEN 204 2S
	33.3							2	0.43	LEN 204 2F
	38.5							3	0.45	UYN 204 2S
	41.6							4	0.48	LYN 204 2F
25	36	27	14	130	99	68	16	6	0.66	LKN 205 2F + H2305
	35.5	27	14	130	99	68	16	1	0.58	UEN 205 2S
	35.8							2	0.61	LEN 205 2F
	39.5							3	0.61	UYN 205 2S
	42.9							4	0.66	LYN 205 2F
	28							5	0.56	LSN 205 2F
30	40.5	30.5	14	148	117	80	16	6	0.98	LKN 206 2F + H2306
	39	30.5	14	148	117	80	16	1	0.84	UEN 206 2S
	40.2							2	0.90	LEN 206 2F
	44.7							3	0.90	UYN 206 2S
	48.1							4	0.97	LYN 206 2F
	32							5	0.98	LSN 206 2F
35	44.8	34	16	161	130	96	16	6	1.20	LKN 207 2F + H2307
	42.3	34	16	161	130	96	16	1	1.20	UEN 207 2S
	44.5							2	1.27	LEN 207 2F
	48.4							3	1.32	UYN 207 2S
	51.3							4	1.40	LYN 207 2F
	34.3							5	1.29	LSN 207 2F
40	48.5	36	16	175	144	100	16	6	1.60	LKN 208 2F + H2308
	46.3	36	16	175	144	100	16	1	1.58	UEN 208 2S
	51.2							2	1.69	LEN 208 2F
	53.7							3	1.72	UYN 208 2S
	55.9							4	1.81	LYN 208 2F
	38							5	1.73	LSN 208 2F
50	52.5	38	18	188	148	108	19	7	1.95	LKN 209 2F + H2309

\* All bearing units are available from Ductile Cast Iron.

Shaft d	Dimensions (mm)							fig.	Mass kg	Designation
	A	A <sub>1</sub>	A <sub>2</sub>	H	J	L	N			
45	47.8	38	18	188	148	108	19	1	1.73	UEN 209 2S
	52.2							2	1.84	LEN 209 2F
	54.7							3	1.84	UYN 209 2S
	56.9							4	1.96	LYN 209 2F
	39.5							5	1.86	LSN 209 2F
	58.5	40	18	195	157	115	19	6	2.10	LKN 210 2F + H2310
50	49.6	40	18	195	157	115	19	1	1.98	UEN 210 2S
	54.6							2	2.13	LEN 210 2F
	54.7							3	2.12	UYN 210 2S
	60.1							4	2.31	LYN 210 2F
	40.5							5	2.27	LSN 210 2F
	63.5	44	18	220	184	130	19	6	3.26	LKN 211 2F + H2311
55	58.4	44	18	220	184	130	19	2	3.12	LEN 211 2F
	60.9							3	3.09	UYN 211 2S
	68.6							4	3.30	LYN 211 2F
	45							5	3.04	LSN 211 2F
	70	48	18	242	202	140	23	6	4.07	LKN 212 2F + H2312
	60	68.7	48	18	242	202	140	23	2	4.07
69.3								3	3.64	UYN 212 2S
75.8								4	4.27	LYN 212 2F

## 6.6. Y-Bearing Flanged Units with Round Grey Cast Iron Housing "G"

UEG...  
LEG...  
UYG...  
LYG...  
LSG...  
LKG...

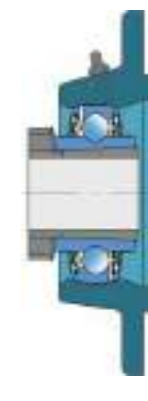
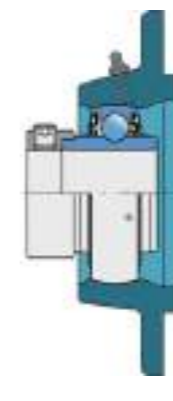
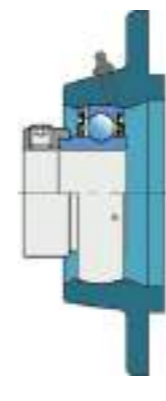
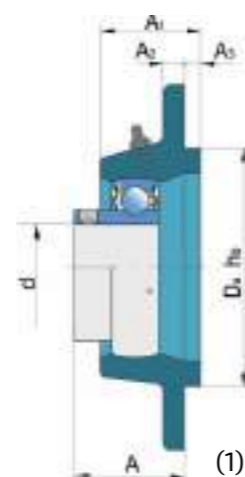
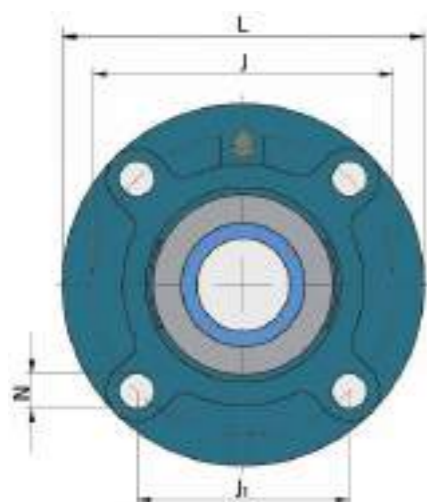

Shaft d	Dimensions (mm)										fig.	Mass kg	Designation
	A	A <sub>1</sub>	A <sub>2</sub>	A <sub>3</sub>	D <sub>a</sub>	J	J <sub>1</sub>	L	N				
20	28.3	25.5	7	5	62	78	55.1	100	12	1	0.65	UEG 204 2S	
	28.3									2	0.67	LEG 204 2F	
	33.5									3	0.69	UYG 204 2S	
	36.6									4	0.72	LYG 204 2F	
25	30	27	7	6	70	90	63.6	115	12	6	0.78	LKG 205 2F + H2305	
	29.5									1	0.95	UEG 205 2S	
	29.5									2	0.98	LEG 205 2F	
	33.5									3	0.98	UYG 205 2S	
	36.9									4	1.03	LYG 205 2F	
	20.5									5	0.93	LSG 205 2F	
30	32	31	8	8	80	100	70.7	125	12	6	1.45	LKG 206 2F + H2306	
	31									1	1.34	UEG 206 2S	
	32.2									2	1.40	LEG 206 2F	
	36.7									3	1.40	UYG 206 2S	
	40.1									4	1.47	LYG 206 2F	
	23									5	1.48	LSG 206 2F	
35	35.3	34	9	8	90	110	77.8	135	14	6	1.60	LKG 207 2F + H2307	
	34.3									1	1.57	UEG 207 2S	
	36.5									2	1.64	LEG 207 2F	
	40.4									3	1.69	UYG 207 2S	
	43.3									4	1.77	LYG 207 2F	
	23.8									5	1.66	LSG 207 2F	
40	38.5	36	9	10	100	120	84.8	145	14	6	2.10	LKG 208 2F + H2308	
	36.3									1	1.78	UEG 208 2S	
	41.2									2	1.89	LEG 208 2F	
	43.7									3	1.92	UYG 208 2S	
	45.9									4	2.01	LYG 208 2F	
	24.5									5	1.93	LSG 208 2F	
45	38.5	38	14	12	105	132	93.3	160	16	6	2.75	LKG 209 2F + H2309	

Shaft d	Dimensions (mm)										fig.	Mass kg	Designation
	A	A <sub>1</sub>	A <sub>2</sub>	A <sub>3</sub>	D <sub>a</sub>	J	J <sub>1</sub>	L	N				
45	35.8	38	14	12	105	132	93.3	160	16	1	2.53	UEG 209 2S	
	40.2									2	2.64	LEG 209 2F	
	42.7									3	2.64	UYG 209 2S	
	44.9									4	2.76	LYG 209 2F	
	24									5	2.66	LSG 209 2F	
	40	40	14	12	110	138	97.6	165	16	6	3.00	LKG 210 2F + H2310	
50	37.6	40	14	12	110	138	97.6	165	16	1	2.78	UEG 210 2S	
	42.6									2	2.93	LEG 210 2F	
	42.7									3	2.92	UYG 210 2S	
	48.1									4	3.11	LYG 210 2F	
	24									5	3.07	LSG 210 2F	
	57	43	15	12	125	150	106.1	185	19	6	3.26	LKG 211 2F + H2311	
55	46.4	43	15	12	125	150	106.1	185	19	2	4.07	LEG 211 2F	
	48.9									3	4.04	UYG 211 2S	
	56.6									4	4.25	LYG 211 2F	
	27.5									5	3.99	LSG 211 2F	
	59	48	15	12	135	160	113.1	195	19	6	4.07	LKG 212 2F + H2312	
	60	56.7	48	15	12	135	160	113.1	195	19	2	5.02	LEG 212 2F
57.3										3	4.59	UYG 212 2S	
63.8										4	5.22	LYG 212 2F	
65		58.9	50	15	14	145	170	120.2	205	19	2	5.85	LEG 213 2F
	67.6									4	6.59	LYG 213 2F	

\* All bearing units are available from Ductile Cast Iron.

## 6.7. Y-Bearing Flanged Units with Round Grey Cast Iron Housing "GS"

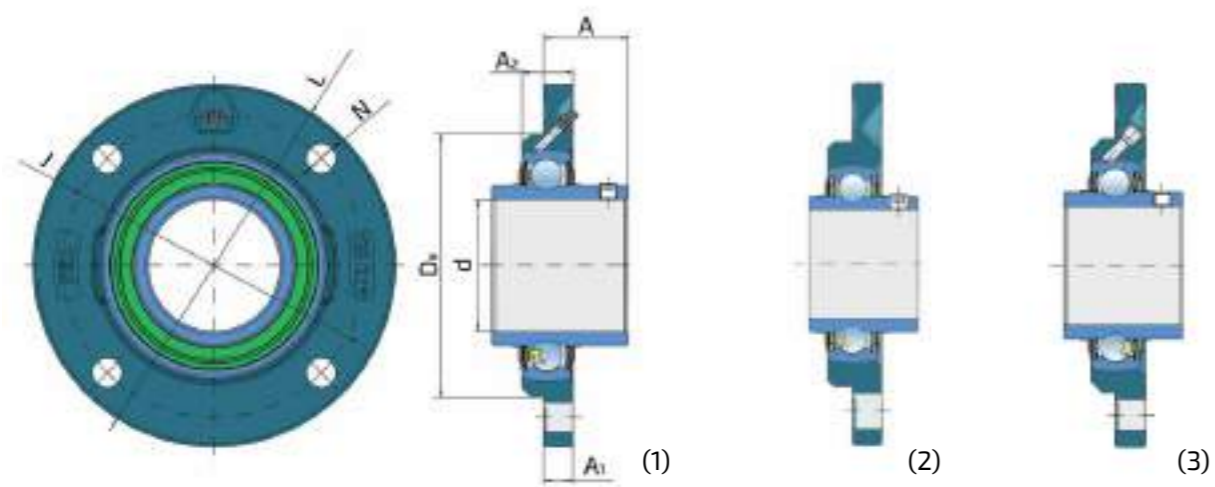

### LEGS...

Shaft		Dimensions (mm)							fig.	Mass kg	Designation
d	A	A <sub>1</sub>	A <sub>2</sub>	D <sub>a</sub>	L	J	N				
40	29.2	11.5	23	100	145	120	11.5	2	1.656	LEGS 208 2F.H	
55	33.4	15	27.5	125	185	150	18	2	3.074	LEGS 211 2F.H	
69.9	39.7	18	32	150	215	177	18	3	4.889	LEGS 214 2F	
75	44.5	18	32	160	220	184	18	1	5.446	LEGS 215 2F.C77.8	
80	51.3	18	31	160	220	184	18	1	5.308	LEGS 216 2F.C82.6	

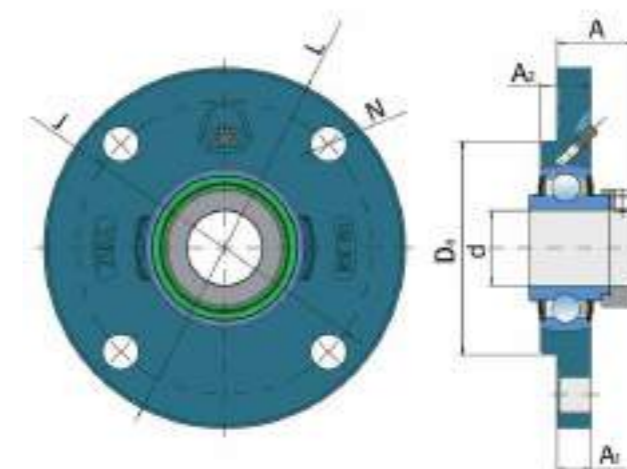

### LYGS...

Shaft		Dimensions (mm)							Mass kg	Designation
d	A	A <sub>1</sub>	A <sub>2</sub>	D <sub>a</sub>	L	J	N			
40	41.9	18	27	115	194	158	19	3.721	LYGS 308 2F	



## 6.8. Y-Bearing Take - Up Units with Grey Cast Iron Housings "T"

UET...  
LET...  
UYT...  
LYT...  
LST...  
LKT...

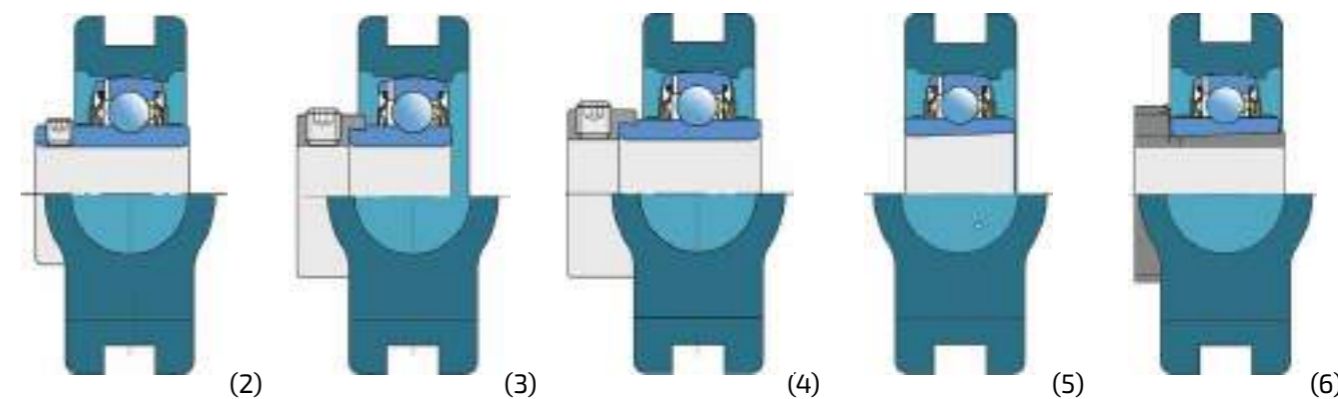
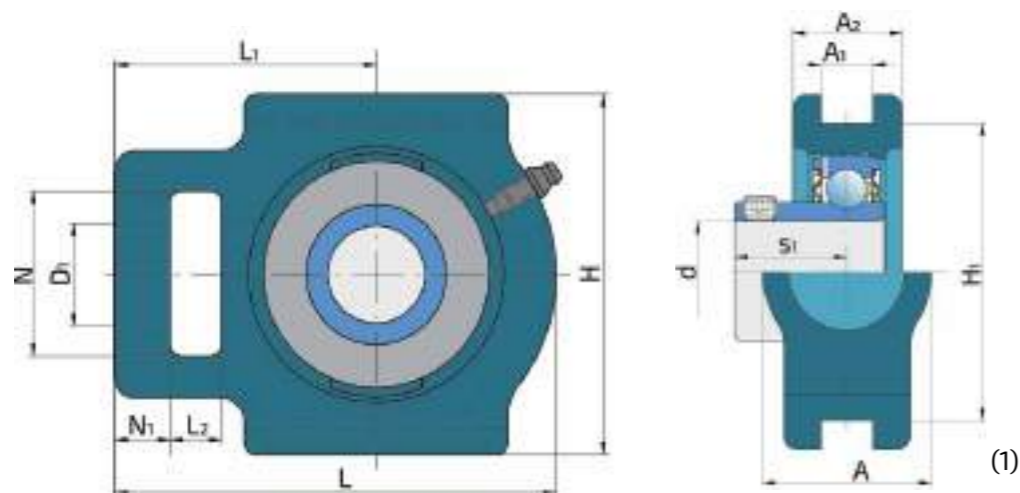

Shaft d	Dimensions (mm)											fig.	Mass kg	Designation	
	A	A <sub>1</sub>	A <sub>2</sub>	D <sub>1</sub>	H	H <sub>1</sub>	L	L <sub>1</sub>	L <sub>2</sub>	N	N <sub>1</sub>				s <sub>1</sub>
20	34	13.5	25	19	92	76	97	62	16	32	10	18.3	1	0.89	UET 204 2S
													2	0.91	LET 204 2F
													3	0.93	UYT 204 2S
													4	0.96	LYT 204 2F
													6	0.94	LKT 205 2F + H2305
25	34	13.5	25	19	91	76	100	64	16	33	10	19.5	1	0.85	UET 205 2S
													2	0.88	LET 205 2F
													3	0.88	UYT 205 2S
													4	0.93	LYT 205 2F
													5	0.85	LST 205 2F
30	37	13.5	28	22	104	89	114	70	16	37	10	25	6	1.37	LKT 206 2F + H2306
													1	1.21	UET 206 2S
													2	1.27	LET 206 2F
													3	1.27	UYT 206 2S
													4	1.34	LYT 206 2F
													5	1.21	LST 206 2F
35	37	13.5	30	22	103	89	129	78	17	38	12	29.5	6	1.66	LKT 207 2F + H2307
													1	1.50	UET 207 2S
													2	1.57	LET 207 2F
													3	1.62	UYT 207 2S
													4	1.70	LYT 207 2F
40	49	17.5	33	29	115	101	145	88	19	50	15	31.5	6	2.43	LKT 208 2F + H2308
													1	2.23	UET 208 2S
													2	2.34	LET 208 2F
													3	2.37	UYT 208 2S
													4	2.46	LYT 208 2F
													5	2.26	LST 208 2F
40	49	17.5	35	29	117	101	144	87	19	49	15	35	6	2.47	LKT 209 2F + H2309

Shaft d	Dimensions (mm)											fig.	Mass kg	Designation	
	A	A <sub>1</sub>	A <sub>2</sub>	D <sub>1</sub>	H	H <sub>1</sub>	L	L <sub>1</sub>	L <sub>2</sub>	N	N <sub>1</sub>				s <sub>1</sub>
45	49	17.5	35	29	117	101	144	87	19	49	15	25.8	1	2.23	UET 209 2S
													2	2.34	LET 209 2F
													3	2.34	UYT 209 2S
													4	2.46	LYT 209 2F
													5	2.25	LST 209 2F
													6	2.63	LKT 210 2F + H2310
50	49	17.5	36	29	117	101	149	90	19	49	16	27.6	1	2.28	UET 210 2S
													2	2.43	LET 210 2F
													3	2.42	UYT 210 2S
													4	2.61	LYT 210 2F
													5	2.34	LST 210 2F
													6	4.16	LKT 211 2F + H2311
55	64	27	41	35	146	130	171	106	25	64	19	33.4	2	4.02	LET 211 2F
													3	3.99	UYT 211 2S
													4	4.20	LYT 211 2F
													5	3.99	LST 211 2F

\* All bearing units are available with Ductile Cast Iron.

## 6.9. Y-Bearing Flanged Units with Round Pressed Steel Housing "C"

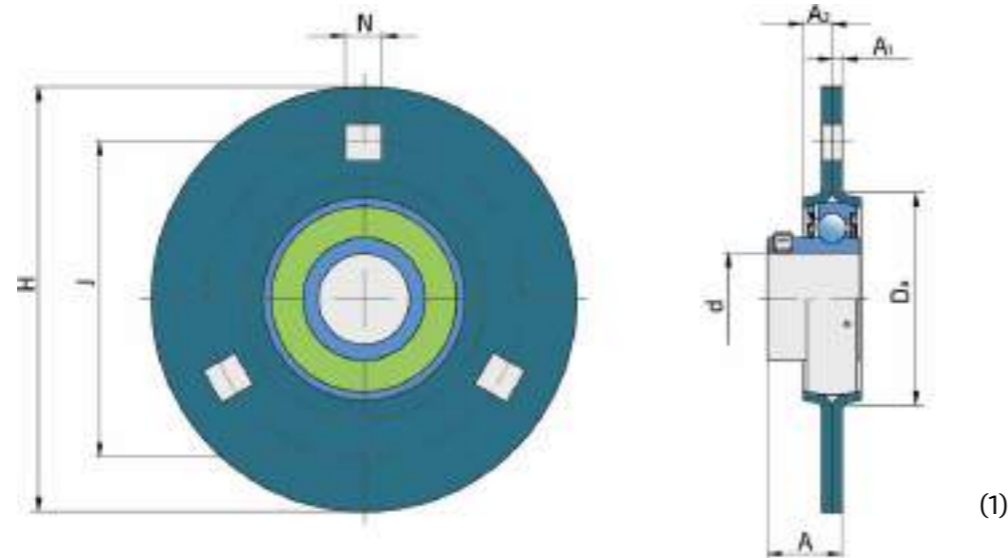

UEC...  
LEC...  
UYC...  
LYC...

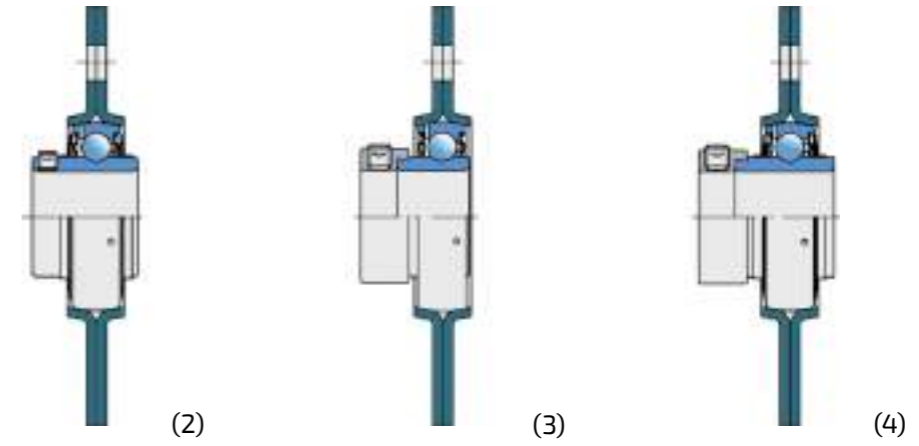

Shaft d	Dimensions (mm)							Perm. load (kN)		fig.	Mass kg	Designation
	A	A <sub>1</sub>	A <sub>2</sub>	D <sub>a</sub>	H	J	N	rad.	axial			
17	17.9	2	7	49	81	63	7.1	2.5	1.2	1	0.20	UEC 203 2S
	17.9									2	0.22	LEC 203 2F
	24.1									3	0.24	UYC 203 2S
	24.3									4	0.26	LYC 203 2F
20	20.3	2	8	55	91	71.5	8.7	3.3	1.6	1	0.28	UEC 204 2S
	20.3									2	0.30	LEC 204 2F
	25.5									3	0.32	UYC 204 2S
	28.6									4	0.35	LYC 204 2F
25	21.5	2	9	60	95	76	8.7	3.6	1.8	1	0.33	UEC 205 2S
	21.8									2	0.36	LEC 205 2F
	25.5									3	0.36	UYC 205 2S
	28.9									4	0.41	LYC 205 2F
30	23.5	2.5	9.5	71	112	90.5	10.5	5.0	2.5	1	0.52	UEC 206 2S
	24.7									2	0.58	LEC 206 2F
	29.2									3	0.58	UYC 206 2S
	32.6									4	0.65	LYC 206 2F
35	25.8	2.5	10.5	81	122	100	10.5	6.5	3.2	1	0.69	UEC 207 2S
	28									2	0.76	LEC 207 2F
	31.9									3	0.81	UYC 207 2S
	34.8									4	0.89	LYC 207 2F

Shaft d	Dimensions (mm)							Perm. load (kN)		fig.	Mass kg	Designation
	A	A <sub>1</sub>	A <sub>2</sub>	D <sub>a</sub>	H	J	N	rad.	axial			
40	28.8	3.5	11	91	148	119	13.5	7.5	3.7	1	1.16	UEC 208 2S
	33.7									2	1.27	LEC 208 2F
	36.2									3	1.30	UYC 208 2S
	38.4									4	1.39	LYC 208 2F
45	29.3	3.5	11.5	96	149	120.5	13.5	8.3	4.1	1	1.23	UEC 209 2S
	33.7									2	1.34	LEC 209 2F
	36.2									3	1.34	UYC 209 2S
	38.4									4	1.46	LYC 209 2F
50	31.6	4	12	102	155	127	13.5	9	4.5	1	1.44	UEC 210 2S
	36.6									2	1.59	LEC 210 2F
	36.7									3	1.58	UYC 210 2S
	42.1									4	1.77	LYC 210 2F
55	37.4	4	12.5	112	167	138	13.5	9.5	4.8	2	2.02	LEC 211 2F
	39.9									3	1.99	UYC 211 2S
	47.6									4	2.20	LYC 211 2F
60	43.7	4	13	122	176	148	13.5	9.5	4.8	2	2.67	LEC 212 2F
	44.3									3	2.24	UYC 212 2S
	50.8									4	2.87	LYC 212 2F

\* Housing C 208 and larger have 4 locking holes.

\* All combinations with other types of Y bearings are possible.

### 6.10. Y-Bearing Flanged Units with Triangular Pressed Steel Housing "D"

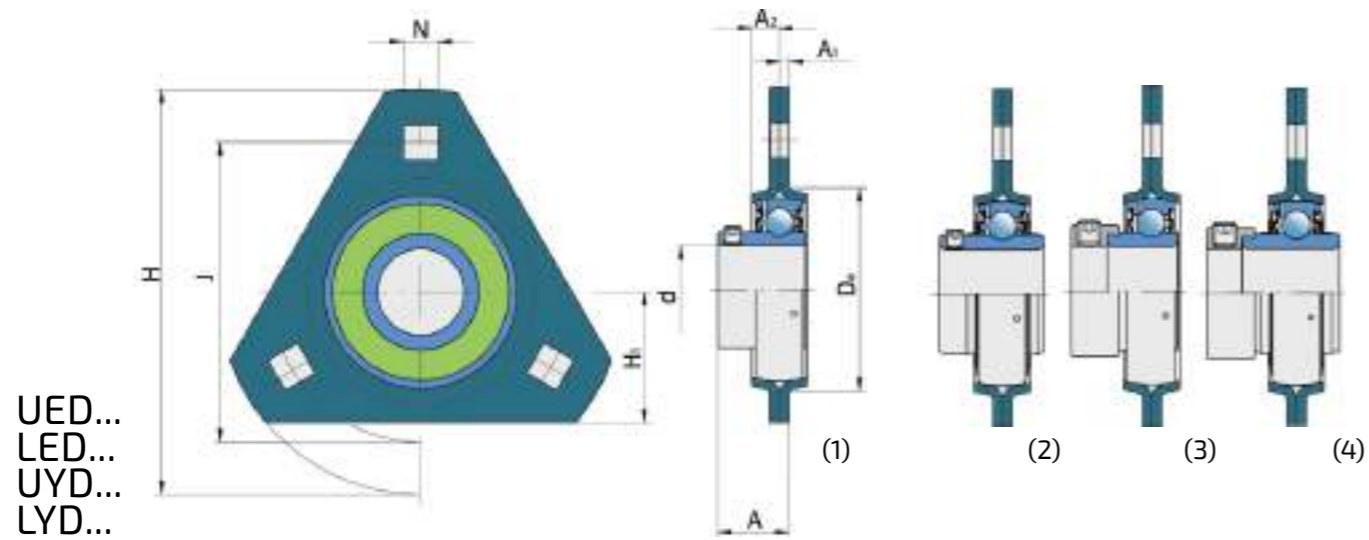

UED...  
LED...  
UYD...  
LYD...

Shaft d	Dimensions (mm)							Perm.load (kN)			fig.	Mass kg	Designation
	A	A <sub>1</sub>	A <sub>2</sub>	D <sub>a</sub>	H	H <sub>1</sub>	J	rad.	axial				
25	21.5	2	9	60	95	34	76	8.7	3.6	1.8	1	0.31	UED 205 2S
	21.8										2	0.34	LED 205 2F
	25.5										3	0.34	UYD 205 2S
	28.9										4	0.39	LYD 205 2F
30	23.5	2.5	9.5	71	112	38	90.5	10.5	5.0	2.5	1	0.43	UED 206 2S
	24.7										2	0.49	LED 206 2F
	29.2										3	0.49	UYD 206 2S
	32.6										4	0.56	LYD 206 2F
35	25.8	2.5	10.5	81	122	45	100	10.5	6.5	3.2	1	0.65	UED 207 2S
	28										2	0.72	LED 207 2F
	31.9										3	0.77	UYD 207 2S
	34.8										4	0.85	LYD 207 2F

### 6.11. Y-Bearing Flanged Units with Oval Pressed Steel Housing "P"

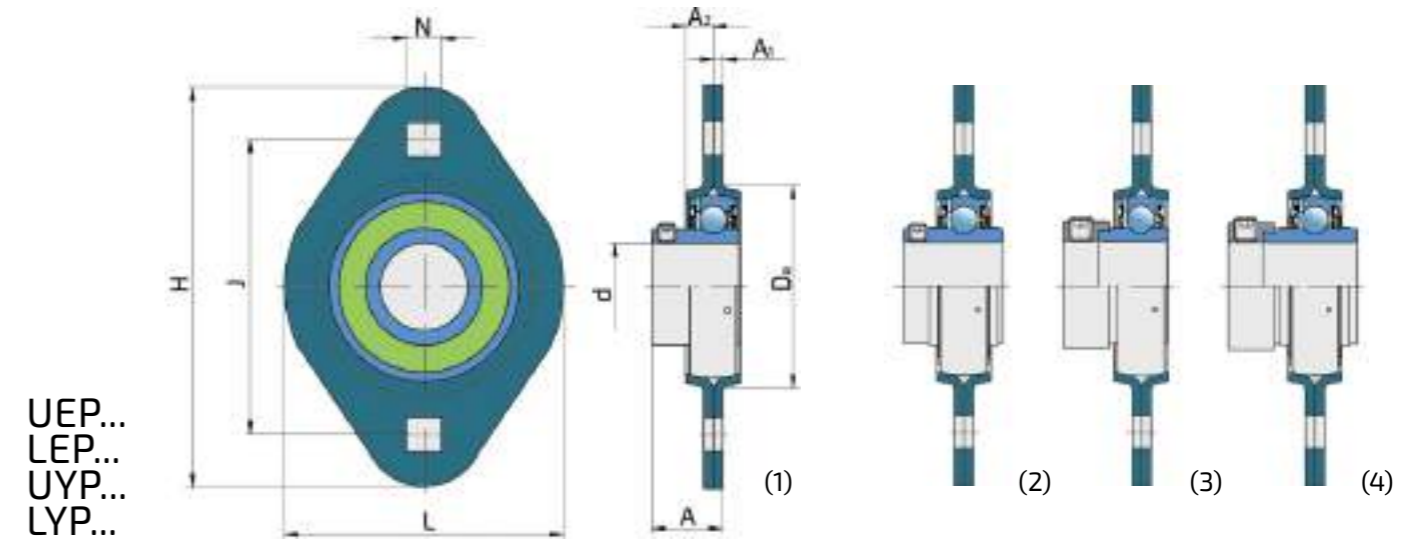

UEP...  
LEP...  
UYP...  
LYP...

Shaft d	Dimensions (mm)							Perm.load (kN)			fig.	Mass kg	Designation
	A	A <sub>1</sub>	A <sub>2</sub>	D <sub>a</sub>	H	L	J	rad.	axial				
17	17.9	2	7	49	81	59	63	7.1	2.5	1.2	1	0.15	UEP 203 2S
	17.9										2	0.17	LEP 203 2F
	24.1										3	0.19	UYP 203 2S
	24.3										4	0.21	LYP 203 2F
20	20.3	2	8	55	91	67	71.5	8.7	3.3	1.6	1	0.21	UEP 204 2S
	20.3										2	0.23	LEP 204 2F
	25.5										3	0.25	UYP 204 2S
	28.6										4	0.28	LYP 204 2F
25	21.5	2	9	60	95	71	76	8.7	3.6	1.8	1	0.26	UEP 205 2S
	21.8										2	0.29	LEP 205 2F
	25.5										3	0.29	UYP 205 2S
	28.9										4	0.34	LYP 205 2F
30	23.5	2.5	9.5	71	112	84	90.5	10.5	5.0	2.5	1	0.40	UEP 206 2S
	24.7										2	0.46	LEP 206 2F
	29.2										3	0.46	UYP 206 2S
	32.6										4	0.53	LYP 206 2F
35	25.8	2.5	10.5	81	122	94	100	10.5	6.5	3.2	1	0.60	UEP 207 2S
	28										2	0.67	LEP 207 2F
	31.9										3	0.72	UYP 207 2S
	34.8										4	0.80	LYP 207 2F
40	28.8	3.5	11	91	148	100	119	13.5	7.5	3.7	1	0.83	UEP 208 2S
	33.7										2	0.94	LEP 208 2F
	36.2										3	0.97	UYP 208 2S
	38.4										4	1.06	LYP 208 2F

\* All combinations with other types of Y bearings are possible.

\* All combinations with other types of Y bearings are possible.

# Agricultural Bearing Units - Special Solutions

7.1. Bearing Units Type 2TB.....	70
7.2. Bearing Units Type 2TC and 2PC.....	71
7.3. ARMOR Bearing Units .....	72



## 7.1. Bearing Units Type 2TB

By the requests of the agricultural equipment manufacturers in addition to the standard Y-program FKL D00 Temerin has developed special versions of bearings with a variety of improvements in construction, primarily in order to extend the life of bearing to the end-users satisfaction. In agriculture, good sealing means durability and accordingly LEFN 2xx 2TB series of bearing units with better sealing have been developed. They carry an additional designation 2TB, but have the same size as series LEFN 2xx 2F.

### Triple-lip seals (2T)

Instead of one-lip seals triple-lip seals are installed and this solution has been implemented for number of years. Seal has a steel reinforcement which is further zinc galvanized so it has good anti corrosion protection. Strong triple lips are made of NBR rubber resistant to lubricants and fuels. Between the lips there are 3 compartments for grease storage, which retain impurities, this preventing the penetration of dirt to the balls. More detailed info about 2T sealing see on page 10.

### Protective flinger

As additional protection from rough dirt (grass, wires, strings,...) and mechanical impact of foreign matters, increased thickness 1,5-2 mm reinforced rubber protection flinger was added. Increased thickness and surface protection ensure longer operation life despite the influence of various external atmospheric agents (water, acids,...).

Flinger is fitted interference a solid flap on the inner ring so it provides a good additional protection. Flinger has protection function to the seal. Since mounted in front of it, prevents rough dirt penetration and provide protection against mechanical impact.

### Lubrication

These series are enabled for additional lubrication by means of lubricators. Cone countersinks are made at angle of 120°, one per side. This results in better flow and entry of grease which makes easier to bring grease in the contact zone of balls and raceways. Grease flow is better due to the increased diameter of the intake grease hole.

### Housing material

Material selected for 2TB housings is Grey Cast Iron EN-GJL-200 but also can be ductile iron EN-GJS-500-7 which has many advantages comparing to Grey Cast Iron in terms of the strength of structure, resistance to shocks, vibrations, abrasion and therefore longer life span.

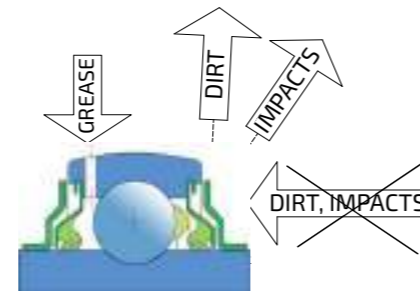

Fig.15. Sealing 2TB

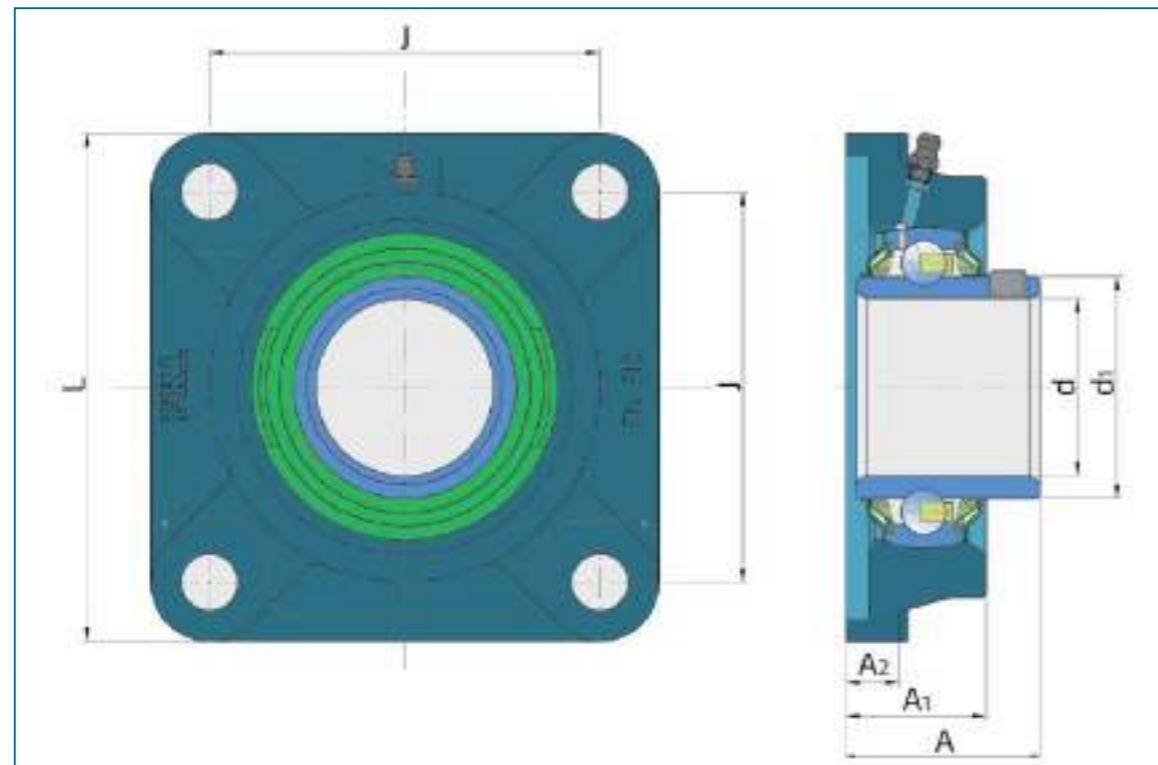

Fig. 16. LEFN 210 2TB

## 7.2. Bearing Units Type 2TC and 2PC

FKL D00 Temerin has developed another series of bearing units for agriculture named LEFN 2xx 2TC and 2PC.

Bearing units for disc harrows, rollers and similar reduced tillage machines, where the grass is present in excessive amounts and high probability for the machine to encounter problems with leftover ropes or winded wires on rotating shaft which tend to destroy the sealing (and a whole bearing) are developed using tin caps protection (C designation in suffix).

### Bearing Units Type 2TC

#### Triple-lip seals (2T)

Instead of one-lip seals triple-lip seals are installed and this solution has been implemented for number of years. Seal has a steel reinforcement which is further zinc galvanized so it has good anti corrosion protection. Strong triple lips are made of NBR rubber resistant to lubricants and fuels. Between the lips there are 3 compartments for grease storage, which retain impurities, this preventing the penetration of dirt to the balls. More detailed info about 2T sealing see on page 10.

### Cap

As additional protection from rough dirt (grass, wire, soil, mud,...) and mechanical impact of foreign matter e.g. rubble, protective sheet of the series 2TB, has been replaced with an increased thickness steel cap (1,5-2 mm), that covers the whole front of the bearing unit. Increased thickness and surface protection improves longer operation life. The tin is mounted below the cast housing tightening screw. It also has protective function for the triple and five-lips seal, because it is mounted in front of the seal and prevents penetration of rough dirt

to the seal and protects it from mechanical impact.

### Lubrication

These series are enabled for additional lubrication by means of lubricators.

Cone countersinks are made at angle of 120°, one per side. This results in a better flow and entry of grease which makes easier to bring grease in the contact zone of balls and raceways.

Grease flow is better due to the increased diameter of the intake grease hole and number of holes is increased from 2 to 3.

### Housing material

Material selected for 2TC housings is Grey Cast Iron EN-GJL-200 but also can be ductile iron EN-GJS-500-7 which has many advantages comparing to Grey Cast Iron in terms of the strength of structure, resistance to shocks, vibrations, abrasion and therefore longer life span. Color of these housings can be standard factory blue or black.

### Bearing Units Type 2PC

Bearing units named LEFN 2xx 2PC have the same performance as bearing units LEFN 2xx 2TC with only difference regarding the sealing. Instead of triple-lip seal this unit has five-lip seal.

### Five-lip seal (2P)

Instead triple-lips seals, they are incorporated with newly developed seal, five-lip seal. Seal has a steel reinforcement which is zinc galvanized and has good corrosion protection. Five strong lips are made out of new type NBR rubber, resistant to oils and fuels, and resistant to high temperatures above 110°C. More detailed info about 2P sealing see on page 10.

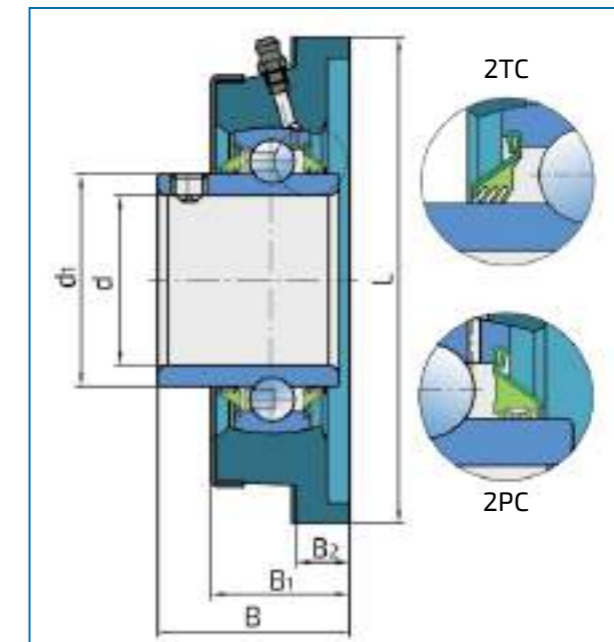
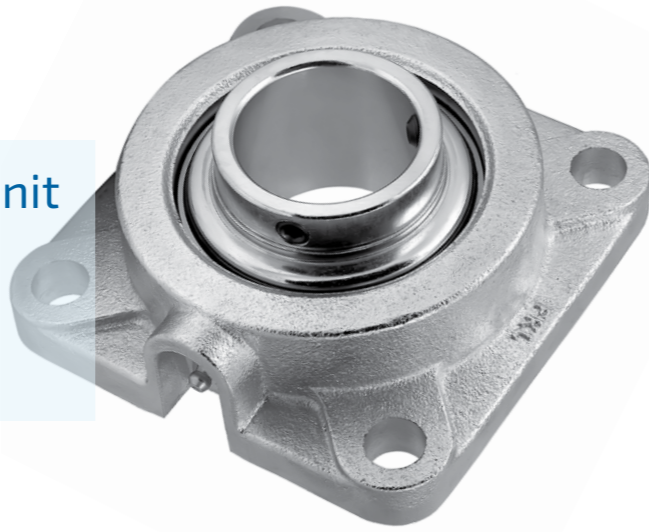

Fig.17. Bearing units type 2TC and 2PC

## 7.3. ARMOR Bearing Unit

### ARMOR LEFG 2xx TDT Bearing Unit PREMIUM CLASS SOLUTION

One of the best sealing system for application in agricultural machinery!



#### Armor Bearing Unit advantages:

- 1** Ductile Cast Iron housing has two and a half times higher tensile strength than Grey Cast Iron housing.
- 2** Iron arc provides perfect protection of the grease nipple.
- 3** The best anti-corrosion coating of unit parts (housing, inner ring and metal cover).
- 4** Two opposite lubrication grooves, on the housing and on the bearing outer ring as well.
- 5** The unique combination of six-lip sealing by front side of the bearing and 3-lip sealing by base side presents today one of the best sealing system for application in agricultural machinery.
- 6** Additional 1 mm metal cover provides reliable mechanical protection.
- 7** The bearing mounting groove is turned to the base side of the housing, which significantly decreases contact of the bearing with mud and other impurities from the front side.
- 8** Locking pin on the outer ring prevents its rotating and ensures the proper way of installation of the bearing into the housing.

Available Armor Bearing Unit sizes 206, 207, 208, 209, 210, 212, 214.

Designation	Material	Yield strength (MPa)	Tensile strength (MPa)	Elongation (%)
EN-GJL-200	Grey Cast Iron	130	200	0,5
EN-GJS-500-7	Ductile Cast Iron	320	500	7

## ARMOR Bearing Unit PREMIUM CLASS SOLUTIONS

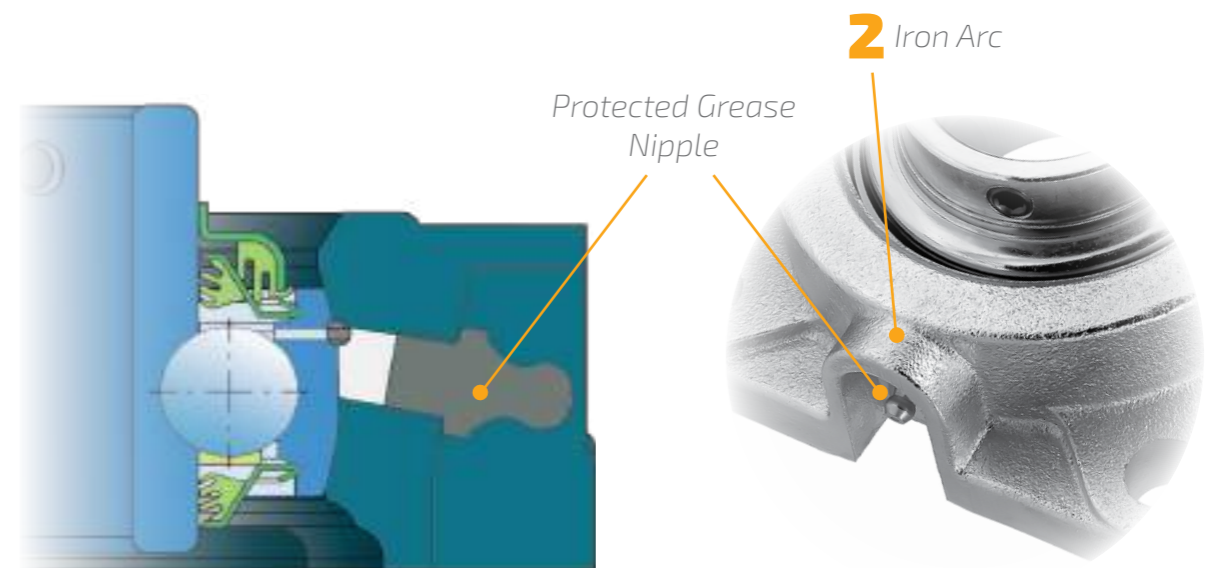
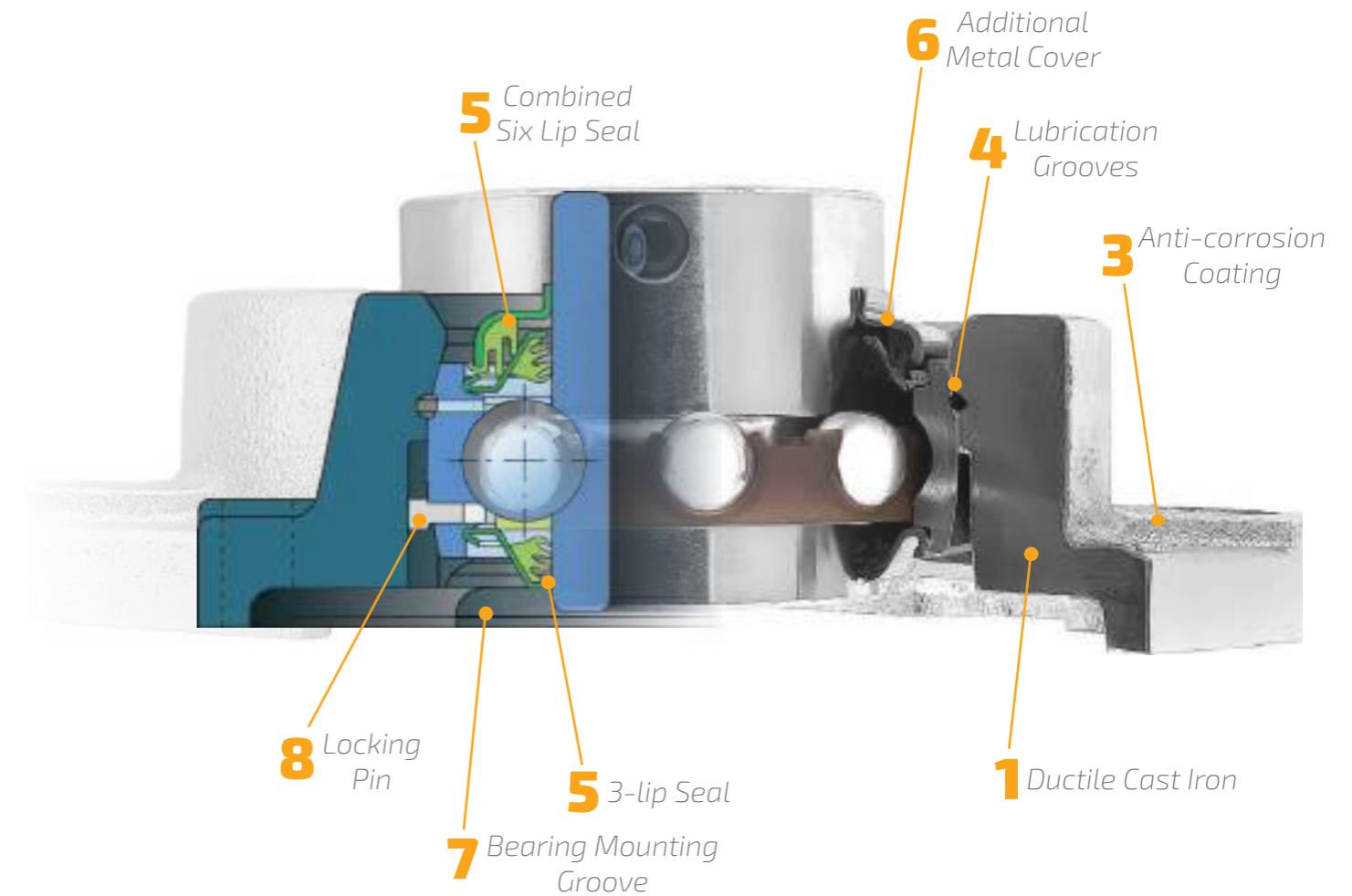

# Agricultural Bearings and Bearing Units

## 8.1. Agricultural Bearings

8.1.1. Round and Square Bore Series with Spherical Outer Ring	
- Non-Relubricable Type .....	76
8.1.2. Round and Square Bore Series with Cylindrical Outer Ring	
- Non-Relubricable Type .....	78
8.1.3. Round Bore Series with Spherical and Cylindrical Outer Ring	
- Relubricable Type .....	80
8.1.4. Square Bore Series with Spherical and Cylindrical Outer Ring	
- Relubricable Type .....	82
8.1.5. Hexagonal Bore Series with Spherical and Cylindrical Outer Ring .....	84
8.2. Agricultural Bearing Units	
8.2.1. Square Bore Series .....	86
8.2.2. Round Series .....	88
8.3. Agricultural Bearings and Bearing Units Overview .....	89



## 8.1. Agricultural Bearings

### 8.1.1. Round and Square Bore Series with Spherical Outer Ring

- Non-Relubricable Type

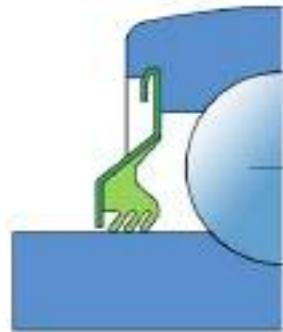

...PPB

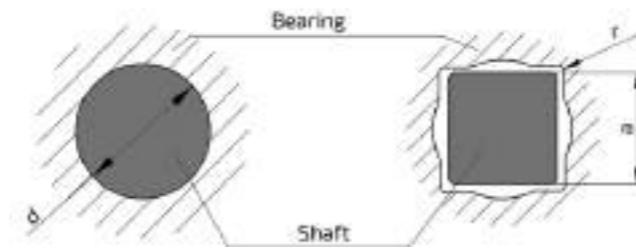

Bore d		D		Dimensions (mm)					
inch	mm	inch	mm	B	C	d <sub>1</sub>			
1.5004	38.11	3.1496	80	1.691	42.96	0.709	18	2.047	52
1.1878	30.17			1.188	30.18	1.188	30.18		
1.1877	30.17			1.188	30.18	0.709	18		
1.5005	38.113			1.691	42.96	1.185	30.1		
1.7717	45	3.3465	85	1.188	30.2	1.188	30.18	2.228	56.6
1.5354	39			1.188	30.18	1.188	30.18		
1.7811	45.24			1.438	36.53	0.866	22		
1.9382	49.23	3.5433	90	1.188	30.18	1.188	30.18	2.461	62.5
1.7850	45.34			1.188	30.18	1.188	30.18		
2.1882	55.58	3.9370	100	1.313	33.34	1.313	33.34	2.721	69.1

#### Shaft size a

1.1811	30	3.1496	80	1.438	36.5	0.709	18	2.047	52
0.9843	25	3.1496	80			0.709	18		
1.1811	30	3.1496	80			1.185	30.1		
1	25.4	3.1496	80			1.188	30.18		
0.9055	23	3.3759	85.75			1.185	30.1		
1.1811	30	3.3759	85.75			1.188	30.18		
7/8	22.2	3.1496	80			0.709	18		
7/8	22.2	3.4386	87.34			1.188	30.18		
1 1/8	28.6	3.4386	87.34			1.188	30.18		
1.2913	32.8	3.3465	85	1.438	36.5	1.189	30.2	2.228	56.6
1.2913	32.8	3.4385	87.34	1.438	36.5	1.189	30.2		
1.2913	32.8	3.3465	85	1.438	36.5	0.748	19		
1.1811	30	3.5433	90	1.772	45	1.142	29		
1 1/8	28.6	3.5433	90	1.188	30.18	1.188	30.18	2.461	62.5
1 1/8	28.6	3.5433	90	1.438	36.53	1.188	30.18		
1.5315	38.9	3.9370	100	1.313	33.34	1.313	33.34	2.720	69.1
1 1/2	38.1	4.1248	104.77	1.75	44.45	1.438	36.53		
1.5315	38.9	4.0772	103.56	1.75	44.5	1.437	36.5		

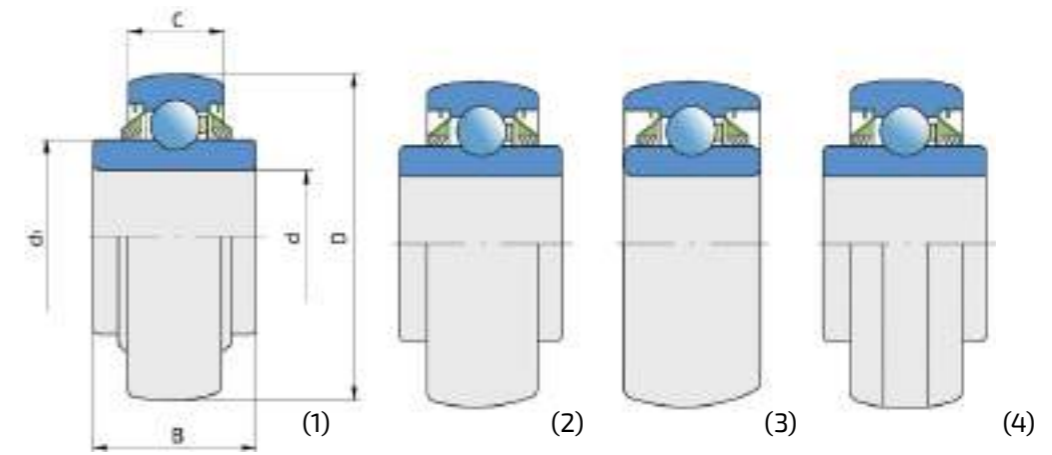

Load ratings (kN)						ROUND BORE		
C <sub>dyn</sub>		C <sub>o</sub>		Mass		Designation	Type	
lbs.	kN	lbs.	kN	lbs.	kg			
7300	32.5	4400	19.8	1.59	0.72	W 208PPB2	1	
				1.60	0.73	W 208PPB4	3	
				1.41	0.64	W 208PPB7	1	
				1.50	0.68	W 208PPB23	1	
7300	32.5	4600	20.4	1.44	0.65	W 209PPB2	3	
				1.65	0.75	W 209PPB4	3	
				1.34	0.62	W 209PPB11	1	
7800	35.0	5200	23.2	1.56	0.71	W 210PPB2	3	
				1.75	0.79	W 210PPB5	3	
9700	43.5	6500	29	2.13	0.97	W 211PPB2	3	

#### SQUARE BORE

7300	32.5	4400	19.8	1.48	0.67	W 208PPB5	1
				1.59	0.72	W 208PPB6	1
				1.74	0.79	W 208PPB8	2
				1.90	0.86	W 208PPB9	2
				2.20	1.00	W 208PPB11	4
				1.98	0.90	W 208PPB12	4
				1.62	0.74	W 208PPB13	1
				2.05	0.93	W 208PPB18	4
				1.87	0.85	W 208PPB19	4
7300	32.5	4600	20.4	1.75	0.79	W 209PPB5	1
				1.85	0.84	W 209PPB7	4
				1.65	0.75	W 209PPB8	1
				2.51	1.14	W 209PPB30	4
7800	35.0	5200	23.2	2.11	0.96	W 210PPB4	3
				2.25	1.02	W 210PPB6	1
9700	43.5	6500	29.0	2.66	1.21	W 211PPB3	3
				4.10	1.86	W 211PPB5	4
				3.83	1.74	W 211PPB6	4



8.1.2. Round and Square Bore Series with Cylindrical Outer Ring  
- Non-Relubricable Type

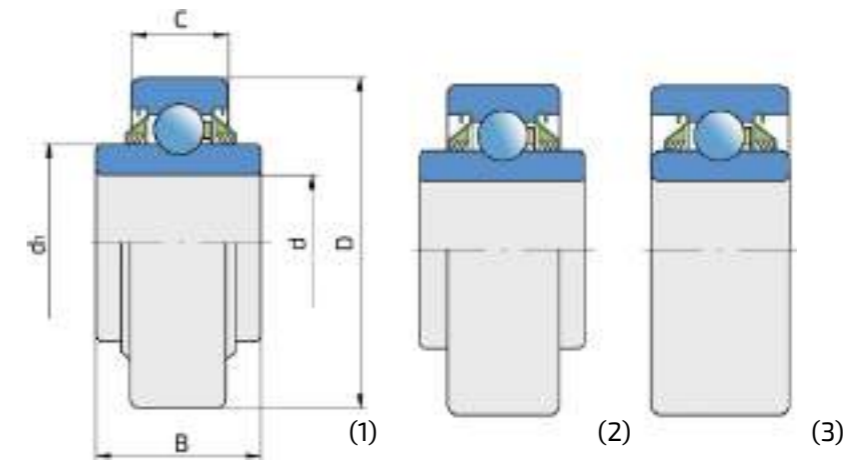
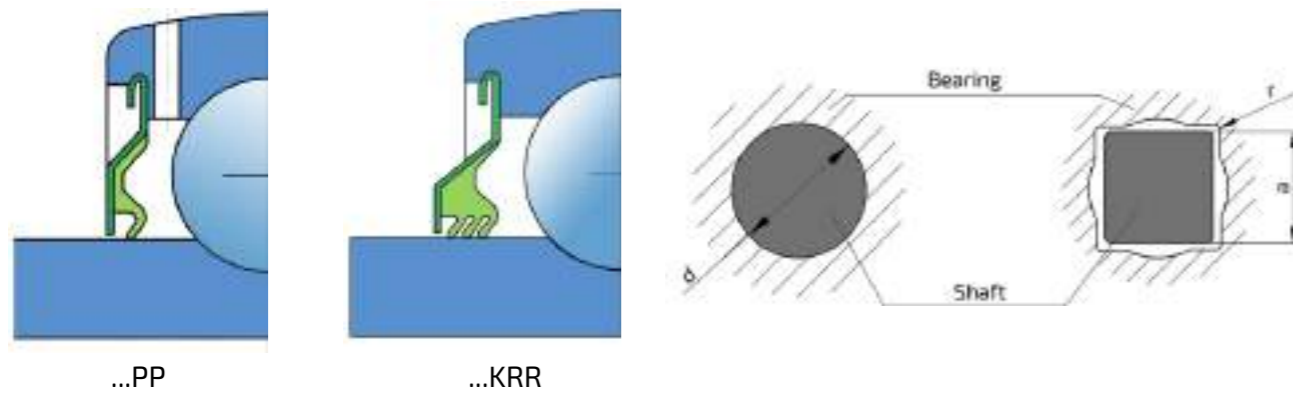

Bore d		D		Dimensions (mm)					
inch	mm	inch	mm	B	C	d <sub>1</sub>			
0.6279	15.95	2	50.8	0.591	15	0.591	15	1.083	27.5
1.5311	38.89	3.1496	80	1.083	27.5	0.827	21	2.024	51.4
1.1878	30.17	3.1496	80	1.188	30.18	1.188	30.18	2.047	52
1.1878	30.17			1.188	30.18	0.709	18		
1.5005	38.113			1.687	42.85	0.827	21		
1.9382	49.23	3.5433	90	1.188	30.18	1.188	30.18	2.461	62.5
2.1882	55.58	3.9370	100	1.313	33.34	1.312	33.34	2.720	69.1

Shaft size a									
1	25.4	2.8346	72	1.772	45	0.945	24	1.815	46.1
1 3/16	30	3.1496	80	1.437	36.5	0.709	18	2.047	52
1	25.4					0.709	18		
1.1811	30					1.185	30.1		
1.1811	30					0.709	18		
1.1811	30	3.3465	85	1.772	45	1.188	30.18	2.228	56.6
1 1/8	28.6	3.5433	90	1.188	30.18	1.188	30.18	2.461	62.5
1.5315	38.9	3.9370	100	1.313	33.34	1.313	33.34	2.720	69.1
1.5315	38.9	4	101.6	1.75	44.5	1.437	36.5		

Load ratings (kN)						ROUND BORE	
C <sub>dyn</sub>		C <sub>o</sub>		Mass		Designation	Type
lbs.	kN	lbs.	kN	lbs.	kg		
2855	12.7	1470	6.55	0.55	0.25	203KRR3	3
5306	23.6	4270	19	1.01	0.46	208KRR4	2
7300	32.5	4400	19.8	1.68	0.76	W 208PP4	3
				1.43	0.65	W 208PP7	1
				1.50	0.68	W 208PP10	1
7800	35.0	5200	23.2	2.67	1.21	W 210PP2	3
				2.33	1.06	W 211PP2	3

SQUARE BORE							
5700	25.5	3400	15.3	1.65	0.75	W 207PP3	1
7300	32.5	4400	19.8	1.50	0.68	W 208PP5	1
				1.62	0.73	W 208PP6	1
				1.66	0.75	W 208PP8	1
				2.50	0.68	W 208PP20	1
7300	32.5	4600	20.4	2.16	0.98	W 209PP3	2
7800	35.0	5200	23.2	1.92	0.87	W 210PP4	3
9700	43.5	6500	29.0	2.67	1.21	W 211PP3	3
				3.48	1.58	W 211PP5	1

8.1.3. Round Bore Series with Spherical and Cylindrical Outer Ring  
– Relubricable Type

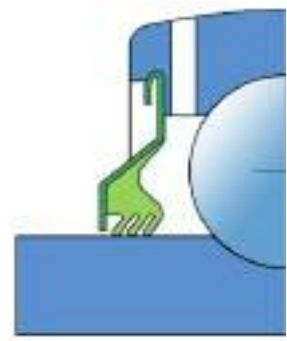

...PP, PPB

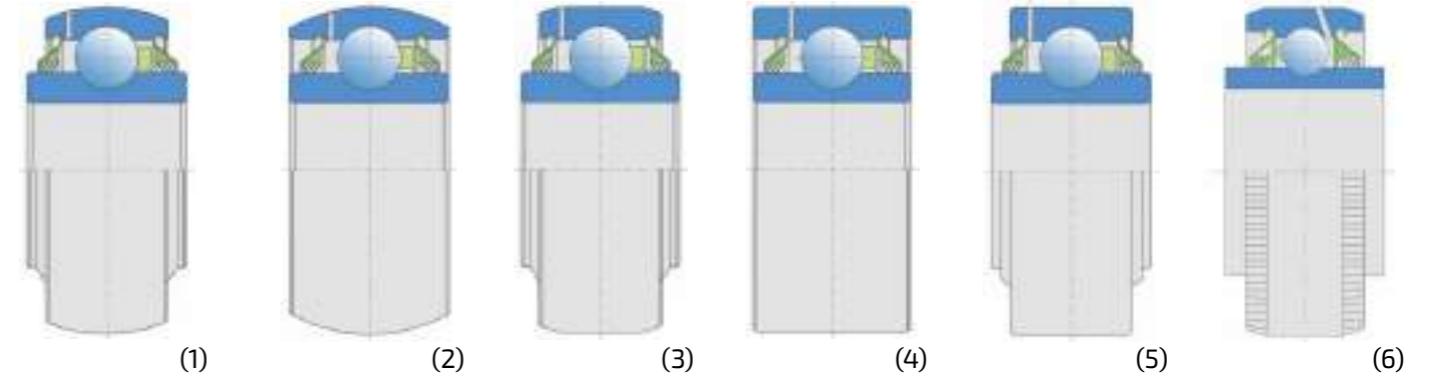
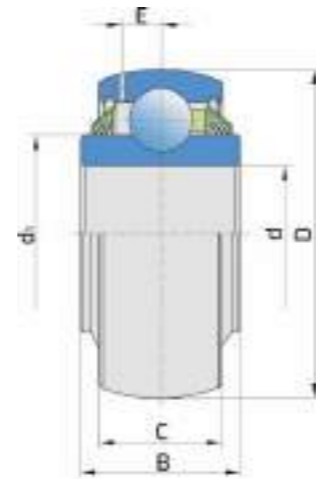
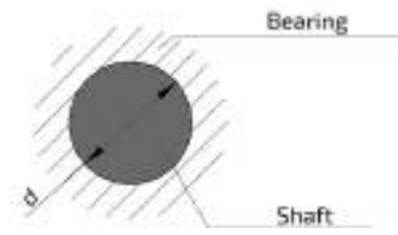

Bore d		D		B		C		d <sub>1</sub>		E	
inch	mm	inch	mm	inch	mm	inch	mm	inch	mm	inch	mm
1.7717	45	3.3465	85	1.189	30.2	1.189	30.2	2.228	56.6	0.256	6.5
1.5350	39			1.188	30.18	1.188	30.18				
1.7811	45.24			1.437	36.5	0.866	22				
1.765	44.831			1.687	42.85	0.866	22				
1.7811	45.24	3.3465	85	1.438	36.53	1.185	30.1				
1.77	44.958	3.4921	88.7	1.687	42.86	1.25	31.75				
1.5748	40	3.3465	85	1.687	42.85	0.866	22				
1.9382	49.23	3.5433	90	1.188	30.18	1.188	30.18	2.461	62.5	0.260	6.6
1.4067	35.73			1.188	30.18	1.188	30.18				
1.7850	45.34			1.188	30.18	1.188	30.18				
1.9449	49.40			1.438	36.53	0.906	23				
2.1882	55.58	3.9370	100	1.313	33.34	1.313	33.34	2.720	69.1	0.280	7.1
2.1882	55.58			1.313	33.34	1.313	33.34				
1.6598	42.16			1.313	33.34	1.313	33.34				
2.1882	55.58			1.313	33.34	0.984	25				
2.1949	55.75			1.563	39.69	0.984	25				
2.1949	55.75			1.563	39.69	0.984	25				
1.9382	49.23			1.313	33.34	1.313	33.34				
1.7850	45.34			1.313	33.34	0.984	25				
1.7850	45.34			1.313	33.34	0.984	25				
2.0201	51.31			2.374	60.3	1.313	33.34				
1.7799	45.21			1.752	44.5	1.313	33.34				
2.0150	51.18			1.313	33.34	0.984	25				
2.1882	55.58			2.187	55.55	0.984	25				
2.1880	55.57			2.187	55.55	0.984	25				
2.1878	55.58			1.575	40	0.984	25				
2.1878	55.7			1.563	39.7	1.323	33.6				
1.78	45.212	3.9790	101.067	2.125	53.975	1.438	36.525	2.720	69.1	0.614	15.6

C <sub>dyn</sub>		Load ratings (kN)		C <sub>0</sub>		Mass		Designation	Type
lbs.	kN	lbs.	kN	lbs.	kg				
7300	32.5	4600	20.4	1.44	0.65			GW 209PPB2	2
				1.65	0.75			GW 209PPB4	2
				1.37	0.62			GW 209PPB11	1
				1.50	0.68			GW 209PPB12	1
				1.41	0.65			GW 209PPB13	1
				2.03	0.92			GW 209PPB30	3
				1.72	0.78			GW 209PPB40	1
7800	35.0	5200	23.2	1.50	0.68			GW 210PPB2	2
				2.25	1.02			GW 210PP3	4
				1.75	0.79			GW 210PPB5	2
				1.75	0.79			GW 210PP9	5
9700	43.5	6500	29.0	3.00	1.36			GW 211PP2	4
				2.62	1.19			GW 211PPB2	2
				3.00	1.36			GW 211PP4	4
				1.85	0.84			GW 211PPB8	1
				2.02	0.92			GW 211PPB9	1
				2.02	0.92			GW 211PP9	5
				2.26	1.03			GW 211PPB10	2
				2.02	0.92			GW 211PPB13	1
				2.02	0.92			GW 211PP13	5
				2.45	1.11			GW 211PP202	5
				2.45	1.11			GW 211PP25	5
				2.00	0.91			GW 211PPB14	1
				2.18	0.99			GW 211PPB15	1
				2.00	0.91			GW 211PPB15X1	1
				2.03	0.92			GW 211PPB16	1
9500	42.5	6500	29.0	2.21	1.03			GW 211PPB20	1
9700	43.5	6500	29.0	3.29	1.49			GW 211PPB21	6

8.1.4. Square Bore Series with Spherical and Cylindrical Outer Ring  
– Relubricable Type

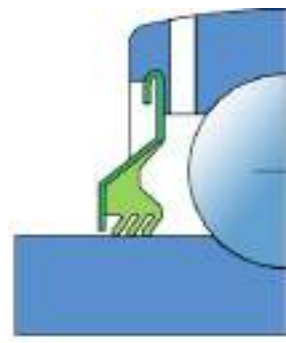

...PP, PPB

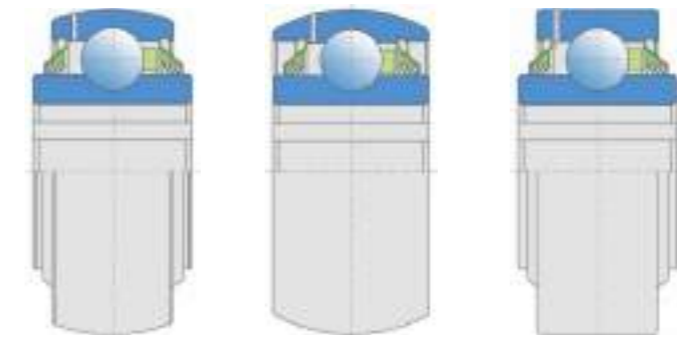
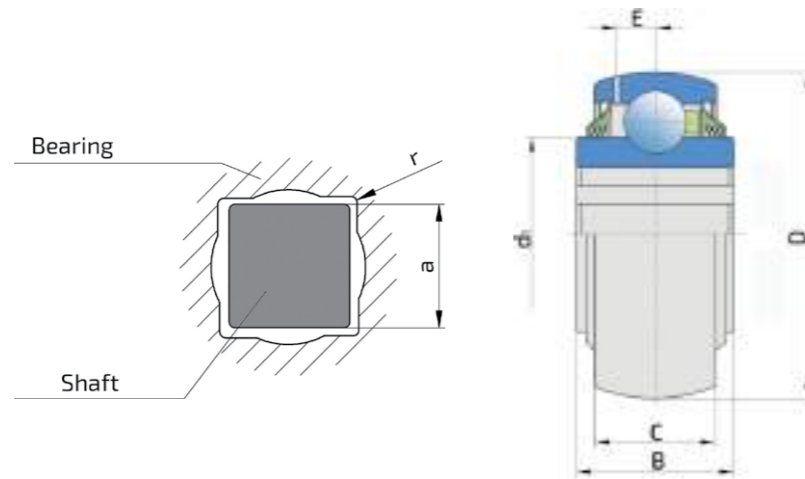

(1) (2) (3)

Schaft size a		Dimensions (mm)									
inch	mm	D		B		C		d <sub>1</sub>		E	
		inch	mm	inch	mm	inch	mm	inch	mm	inch	mm
1 1/8	28.6	3.3756	85.74	1.437	36.5	1.188	30.18	2.05	52	0.256	6.5
1 1/8	28.6	3.5433	90	1.188	30.18	1.188	30.18	2.461	62.5	0.260	6.6
1 1/2	38.1	3.9370	100	1.313	33.34	1.313	33.34	2.72	69.1	0.279	7.1
1 1/2	38.1	3.9370	100	1.75	44.5	1.313	33.34	2.72	69.1	0.279	7.1
1.18	30	3.1496	80	1.437	36.5	0.827	21	2.05	52	0.256	6.5
1	25.4	3.1496	80			0.827	21			0.256	6.5
1.18	30	3.1496	80			1.188	30.1			0.260	6.6
1 1/8	28.6	3.3578	85.74			1.188	30.18			0.26	6.6
1.18	30	3.3465	85	1.772	45	1.188	30.18	2.228	56.6	0.260	6.6
1	25.4			1.772	45	1.188	30.18			0.260	6.6
1.29	32.8			1.437	36.5	1.189	30.2			0.260	6.6
1.29	32.8			1.437	36.5	0.866	22			0.256	6.5
1	25.4			1.687	42.85	0.866	22			0.256	6.5
1.18	30			1.687	42.85	0.866	22			0.256	6.5
1.18	30			1.772	45	0.866	22			0.256	6.5
1.18	30	3.5433	90	1.188	30.18	1.188	30.18	2.461	62.5	0.260	6.6
1.53	38.9	3.9370	100	1.313	33.34	1.313	33.34	2.72	69.1	0.279	7.1
1 1/2	38.1			1.752	44.5	1.313	33.34				
1.59	40.5			1.771	45	0.984	25				
1.54	39.25			2.187	55.55	0.984	25				
1.38	35			2.187	55.55	0.984	25				
1.59	40.5			1.772	45	0.984	25				

		Load ratings (kN)				Mass		Designation	Type
		C		C <sub>0</sub>		lbs.	kg		
lbs.	kN	lbs.	kN	lbs.	kN				
7300	32.5	4400	19.8	2.04	0.925			<b>GW 208PP17</b>	4
7800	35.0	5200	23.2	2.31	1.048			<b>GW 210PP4</b>	3
9700	43.5	6500	29.0	2.79	1.266			<b>GW 211PP3</b>	4
9700	43.5	6500	29.0	2.62	1.188			<b>GW 211PP17</b>	4
7300	32.5	4400	19.8	1.48	0.670			<b>GW 208PPB5</b>	1
				1.48	0.670			<b>GW 208PPB6</b>	1
				1.75	0.790			<b>GW 208PPB8</b>	1
				2.01	0.912			<b>GW 208PPB17</b>	1
7300	32.5	4600	20.4	1.87	0.850			<b>GW 209PPB3</b>	1
				2.16	0.980			<b>GW 209PPB3.X2</b>	1
				1.75	0.794			<b>GW 209PPB5</b>	1
				1.65	0.748			<b>GW 209PPB8</b>	1
				2.09	0.950			<b>GW 209PPB26</b>	1
7900	35.5	4600	20.4	1.37	0.62			<b>GW 209PPB31</b>	1
				2.02	0.920			<b>GW 209PPB32</b>	1
7800	35	5200	23.2	1.75	0.794			<b>GW 210PPB4</b>	2
9700	43.5	6500	29	2.66	1.207			<b>GW 211PPB3</b>	2
				2.56	1.160			<b>GW 211PPB17</b>	1
				2.18	0.990			<b>GW 211PPB40</b>	1
				2.73	1.240			<b>GW 211PPB40.X1</b>	1
				2.87	1.300			<b>GW 211PPB40.X2</b>	1
				2.18	0.990			<b>GW 211PPBJ40</b>	1

### 8.1.5. Hexagonal Bore Series with Spherical and Cylindrical Outer Ring

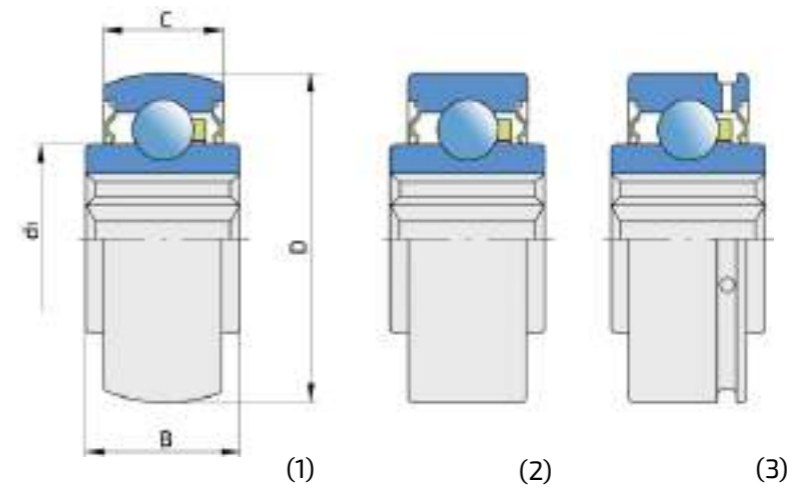
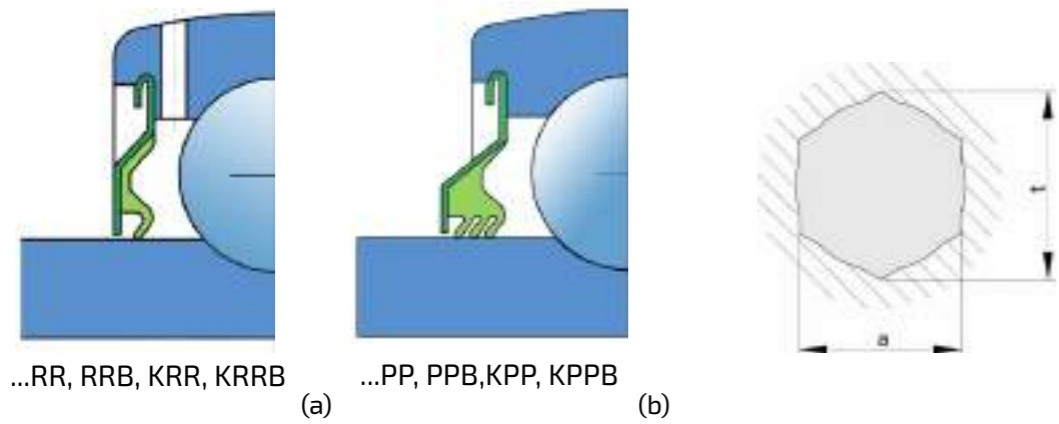

Shaft	Dimensions (mm)											
	a		t <sub>min.</sub>		D		B		C		d <sub>1</sub>	
inch	inch	mm	inch	mm	inch	mm	inch	mm	inch	mm	inch	mm
11/16	0.6949	17.65	0.797	20.24	1.85	47	0.825	20.96	0.551	14	1.110	28.2
11/16	0.6949	17.65	0.797	20.24	1.85	47	0.825	20.96	0.551	14	1.110	28.2
7/8	0.875	22.25	1.010	25.65	2.0472	52	1	25.4	0.591	15	1.323	33.6
1	1.001	25.43	1.152	29.26	2.4409	62	0.945	24	0.630	16	1.563	39.7
11/4	1.251	31.78	1.435	36.46	2.8346	72	1.484	37.7	0.669	17	1.815	46.1
11/4	1.251	31.78	1.435	36.46			0.984	25				
11/8	1.126	28.6	1.298	32.97			1.484	37.7				
11/8	1.126	28.6	1.298	32.97			1.484	37.7				
11/8	1.126	28.6	1.298	32.97			0.984	25				
11/8	1.126	28.6	1.298	32.97			0.984	25				
11/4	1.251	31.78	1.435	36.46			0.984	25				
11/4	1.251	31.78	1.435	36.46			0.984	25				
11/4	1.251	31.78	1.435	36.46			1.496	38				
11/4	1.251	31.78	1.435	36.46	3.1496	80	1.438	36.53	0.709	18	2.047	52
11/4	1.251	31.78	1.435	36.46			1.437	36.5				
11/2	1.501	38.12	1.730	43.94	3.3465	85	1.181	30	0.748	19	2.228	56.6
					3.5433	90			0.866	22	2.461	62.5
11/4	1.251	31.78	1.435	36.46	2.8346	72	1.496	38	0.748	19	1.815	46.1

Load ratings						NON-RELUBRICABLE TYPE			
C <sub>dyn</sub>		C <sub>o</sub>		Mass		Designation			
lbs	kN	lbs	kN	lbs.	kg	Seal Fig. a	Type	Seal Fig. b	Type
2203	9.8	1472	6.55	0.287	0.14	204KRR2	2		
2203	9.8	1472	6.55	0.43	0.14	204KRRB2	1		
3100	14.0	1700	7.8	0.44	0.20			205KPPB2	1
						205KRR2	2		
						205KRRB2	1		
								205PP13	2
								205PPB13	1
4400	19.5	2500	11.3	0.765	0.35			206KPP3	2
				0.76	0.35			206KPPB3	1
				0.75	0.34	206KRR6	2		1
				0.75	0.34	206KRRB6	1		
5700	25.5	3400	15.3	1.00	0.45			207KPP3	2
				0.87	0.40			207KPPB3	1
				1.00	0.45			207KPPB9	1
				1.00	0.45	207KRRB9	1		
				0.87	0.40	207KRRB12	1		
				0.94	0.42	207KRRB12C19	1		
				0.87	0.40	207KRR17	2		
				0.87	0.40	207KRRB17	1		1
				1.44	0.65			207KPPB31	
7300	32.5	4400	19.8	1.45	0.66			W 208PPB16	1
						W 208KRR8	2		
				1.499	0.68			W 208KPP8	2
				1.499				W 208PP16	2
7300	32.5	4600	20.4	1.27	0.58	209KRRB2	1		
								209KPPB2	1
7870	35	5213	23.2	1.76	0.80	210RRB6	1		
						RELUBRICABLE TYPE			
5700	25.5	3400	15.3	1.433	0.65			G207 KPP3 AH16	3

## 8.2. Agricultural Bearing Units

### 8.2.1. Square Series

Type 1.

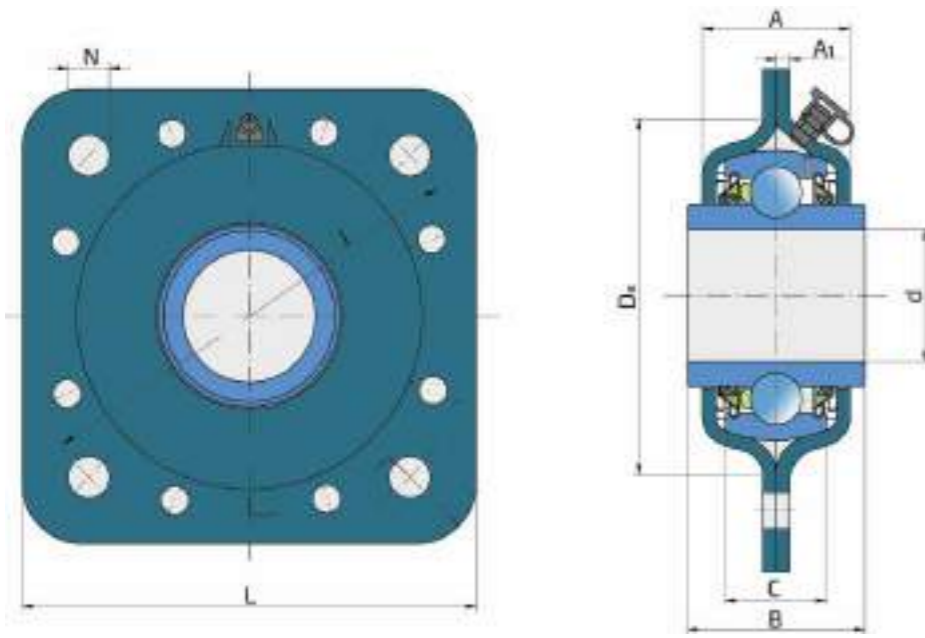

Type 2.

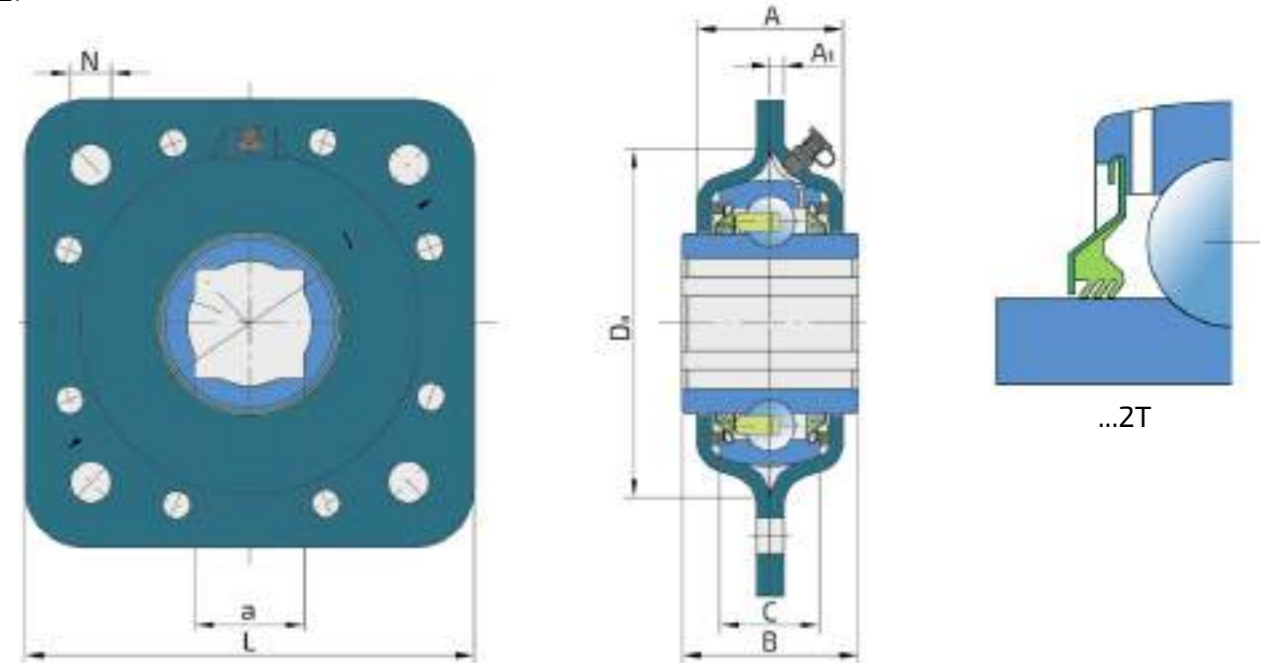

a-square bore mm	Shaft size		Dimensions (mm)							
	inch	d-cylindrical bore mm	B	A	A <sub>1</sub>	C	D <sub>a</sub>	L	J	N
-	1.765	44.831	42.85	39	3.5	22	97	127	114	13.5
25	-	-	42.85							
30	-	-	42.85							
32.8	-	-	42.85							
30	-	-	42.85							
30	-	-	45							
-	1.5004	38.11	42.85							
-	1.5236	38.7	42.85							
-	1.5748	40	42.85							
-	2.1882	55.58	55.55	44.7	4	31.8	113	140	127	13.5
-	2.1882	55.58	55.55			31.8				
40.5	-	-	45			26.5				
39.25	-	-	55.55			25				
35	-	-	55.55							
40.5	-	-	55.55							
40.5	-	-	45							
40.5	-	-	45							
-	2.1654	55	55			31.5				

Recommendations for max. load				Mass		Type	Designation
radial		axial		lbs	kg		
lbs	kN	lbs	kN				
1750	7.7	860	3.8	3.32	1.51	1	GWST 209PPB12
				3.92	1.78	2	GWST 209PPB26
				3.72	1.69	2	GWST 209PPB28
				3.56	1.62	2	GWST 209PPB29
				3.72	1.69	2	GWST 209PPB31
				3.90	1.77	2	GWST 209PPB32
				3.56	1.63	1	GWST 209PPB38
				3.56	1.63	1	GWST 209PPB39
				3.56	1.62	1	GWST 209PPB40
2200	9.8	1150	5.1	4.51	2.05	1	GWST 211PPB15
				4.51	2.05	1	GWST 211PPB15.H
				4.95	2.25	2	GWST 211PPB40
				5.39	2.45	2	GWST 211PPB40.X1
				5.83	2.65	2	GWST 211PPB40.X2
				5.39	2.45	2	GWST 211PPB43
				4.98	2.26	2	GWST 211PPBP40
				4.98	2.26	2	GWST 211PPBJ40
				4.98	2.26	1	LSST 211 X3-3

### 8.2.2. Round Series

Type 1.

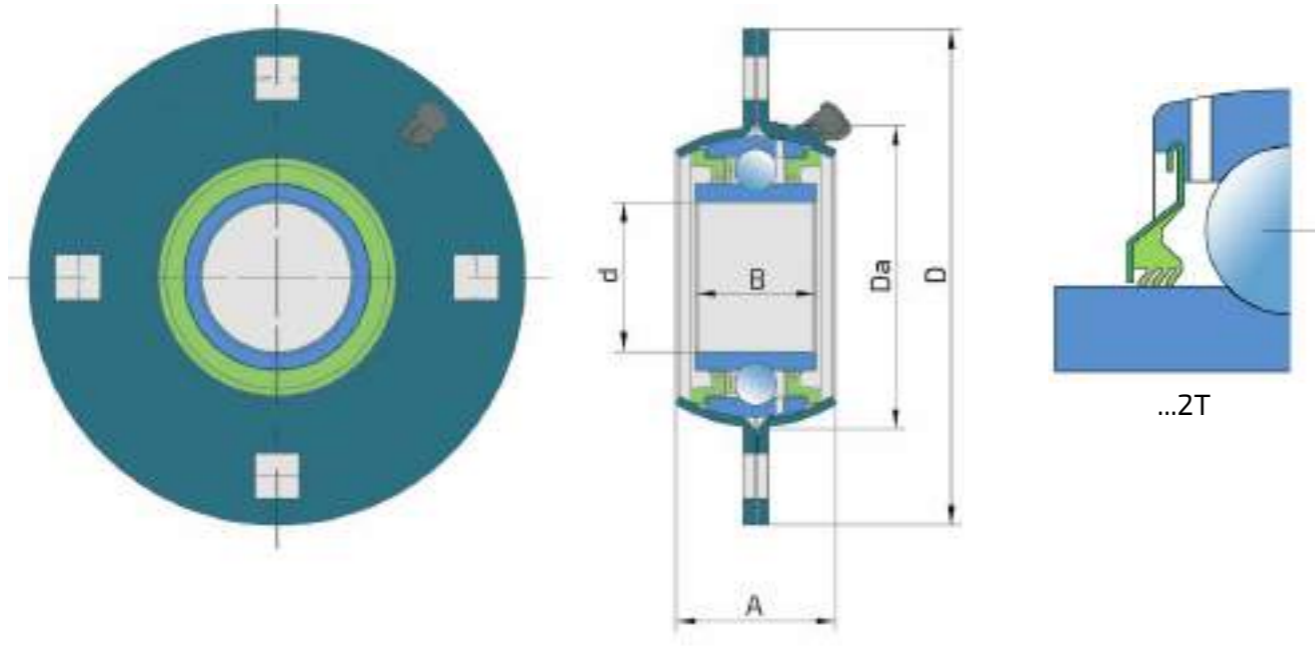

d cylindrical bore	Dimensions (mm)									Recommendations for max. load				Mass		Designation
	B	A	A <sub>1</sub>	C	D <sub>a</sub>	D	J	N		lbs	kN	lbs	kN	lbs	kg	
1.781	45.24	36.53	48.5	3.5	30.1	93	150	120.5	13.5	1750	9.8	860	3.8	4.048	1.836	GWST 209PPB13
2.193	55.7	39.7	56.4	3.5	33.4	111	167	138	13.5	2200	9.8	1150	5.1	5.478	2.485	GWST 211PPB20

\* Maintenance free option is also available

### 8.3. Agricultural Bearings and Bearing Units Overview

Inner Ring	BALL BEARINGS FOR AGRICULTURAL MACHINERY										BEARING UNITS									
	Permanently Lubricated					With Lubrication Groove					Cylindrical Outer Ring					Spherical Outer Ring				
Inner Ring	Cylindrical Outer Ring		Spherical Outer Ring		Cylindrical Outer Ring		Spherical Outer Ring		Cylindrical Outer Ring		Spherical Outer Ring		Cylindrical Outer Ring		Spherical Outer Ring		Cylindrical Outer Ring		Spherical Outer Ring	
	a	D	B	C	a	D	B	C	a	D	B	C	a	D	B	C	a	D	B	C
W207PP3	25.4	72	45	24	W208PP5	28.6	80	36.53	18	GW208PP17	28.6	85.74	36.5	30.18	GW208PP85	30	80	36.5	21	
W208PP5	30	80	36.5	18	W208PP6	25.4	80	36.53	18	GW210PP4	28.6	90	30.18	30.18	GW208PP86	25.4	80	36.5	21	
W208PP6	25.4	80	36.5	18	W208PP7	30.17	80	30.18	18	GW211PP3	38.1	100	33.34	33.34	GW208PP88	30	80	36.5	30.18	
W208PP7	20	47	17.7	14	W208PP8	30	80	36.5	30.1	GW211PP7	38.1	100	44.5	33.34	GW208PP89	25.4	80	36.5	30.18	
W208PP8	30	80	36.5	30.1	W208PP9	25.4	80	36.53	30.18						GW209PP83	30	85	45	39	
W208PP9	30	80	36.5	18	W208PP10	35	72	25	17						GW209PP84	40.5	140	45	44.7	
W208PP10	31.78	72	37.7	17	W208PP11	38.9	101.6	44.5	36.5						GW210PP83	39.25	140	55.55	44.7	
W208PP11	31.78	72	25	17	W208PP12	38.9	101.6	44.5	36.5						GW210PP84	35	140	55.55	44.7	
W208PP12	31.78	72	38	19	W208PP13	28.6	80	36.53	30.18						GW210PP85	40.5	140	55.55	44.7	
W208PP13	31.78	72	36.5	18	W208PP14	28.6	80	36.53	30.18						GW210PP86	40.5	140	55.55	44.7	
W208PP14	31.78	72	36.5	18	W208PP15	38.9	101.6	44.5	36.5						GW210PP87	40.5	140	55.55	44.7	
W208PP15	31.78	72	36.5	18	W208PP16	38.9	101.6	44.5	36.5						GW210PP88	40.5	140	55.55	44.7	
W208PP16	31.78	72	36.5	18	W208PP17	38.9	101.6	44.5	36.5						GW210PP89	40.5	140	55.55	44.7	
W208PP17	31.78	72	36.5	18	W208PP18	38.9	101.6	44.5	36.5						GW210PP90	40.5	140	55.55	44.7	
W208PP18	31.78	72	36.5	18	W208PP19	38.9	101.6	44.5	36.5						GW210PP91	40.5	140	55.55	44.7	
W208PP19	31.78	72	36.5	18	W208PP20	38.9	101.6	44.5	36.5						GW210PP92	40.5	140	55.55	44.7	
W208PP20	31.78	72	36.5	18	W208PP21	38.9	101.6	44.5	36.5						GW210PP93	40.5	140	55.55	44.7	
W208PP21	31.78	72	36.5	18	W208PP22	38.9	101.6	44.5	36.5						GW210PP94	40.5	140	55.55	44.7	
W208PP22	31.78	72	36.5	18	W208PP23	38.9	101.6	44.5	36.5						GW210PP95	40.5	140	55.55	44.7	
W208PP23	31.78	72	36.5	18	W208PP24	38.9	101.6	44.5	36.5						GW210PP96	40.5	140	55.55	44.7	
W208PP24	31.78	72	36.5	18	W208PP25	38.9	101.6	44.5	36.5						GW210PP97	40.5	140	55.55	44.7	
W208PP25	31.78	72	36.5	18	W208PP26	38.9	101.6	44.5	36.5						GW210PP98	40.5	140	55.55	44.7	
W208PP26	31.78	72	36.5	18	W208PP27	38.9	101.6	44.5	36.5						GW210PP99	40.5	140	55.55	44.7	
W208PP27	31.78	72	36.5	18	W208PP28	38.9	101.6	44.5	36.5						GW210PP100	40.5	140	55.55	44.7	
W208PP28	31.78	72	36.5	18	W208PP29	38.9	101.6	44.5	36.5						GW210PP101	40.5	140	55.55	44.7	
W208PP29	31.78	72	36.5	18	W208PP30	38.9	101.6	44.5	36.5						GW210PP102	40.5	140	55.55	44.7	
W208PP30	31.78	72	36.5	18	W208PP31	38.9	101.6	44.5	36.5						GW210PP103	40.5	140	55.55	44.7	
W208PP31	31.78	72	36.5	18	W208PP32	38.9	101.6	44.5	36.5						GW210PP104	40.5	140	55.55	44.7	
W208PP32	31.78	72	36.5	18	W208PP33	38.9	101.6	44.5	36.5						GW210PP105	40.5	140	55.55	44.7	
W208PP33	31.78	72	36.5	18	W208PP34	38.9	101.6	44.5	36.5						GW210PP106	40.5	140	55.55	44.7	
W208PP34	31.78	72	36.5	18	W208PP35	38.9	101.6	44.5	36.5						GW210PP107	40.5	140	55.55	44.7	
W208PP35	31.78	72	36.5	18	W208PP36	38.9	101.6	44.5	36.5						GW210PP108	40.5	140	55.55	44.7	
W208PP36	31.78	72	36.5	18	W208PP37	38.9	101.6	44.5	36.5						GW210PP109	40.5	140	55.55	44.7	
W208PP37	31.78	72	36.5	18	W208PP38	38.9	101.6	44.5	36.5						GW210PP110	40.5	140	55.55	44.7	
W208PP38	31.78	72	36.5	18	W208PP39	38.9	101.6	44.5	36.5						GW210PP111	40.5	140	55.55	44.7	
W208PP39	31.78	72	36.5	18	W208PP40	38.9	101.6	44.5	36.5						GW210PP112	40.5	140	55.55	44.7	
W208PP40	31.78	72	36.5	18	W208PP41	38.9	101.6	44.5	36.5						GW210PP113	40.5	140	55.55	44.7	
W208PP41	31.78	72	36.5	18	W208PP42	38.9	101.6	44.5	36.5						GW210PP114	40.5	140	55.55	44.7	
W208PP42	31.78	72	36.5	18	W208PP43	38.9	101.6	44.5	36.5						GW210PP115	40.5	140	55.55	44.7	
W208PP43	31.78	72	36.5	18	W208PP44	38.9	101.6	44.5	36.5						GW210PP116	40.5	140	55.55	44.7	
W208PP44	31.78	72	36.5	18	W208PP45	38.9	101.6	44.5	36.5						GW210PP117	40.5	140	55.55	44.7	
W208PP45	31.78	72	36.5	18	W208PP46	38.9	101.6	44.5	36.5						GW210PP118	40.5	140	55.55	44.7	
W208PP46	31.78	72	36.5	18	W208PP47	38.9	101.6	44.5	36.5						GW210PP119	40.5	140	55.55	44.7	
W208PP47	31.78	72	36.5	18	W208PP48	38.9	101.6	44.5	36.5						GW210PP120	40.5	140	55.55	44.7	
W208PP48	31.78	72	36.5	18	W208PP49	38.9	101.6	44.5	36.5						GW210PP121	40.5	140	55.55	44.7	
W208PP49	31.78	72	36.5	18	W208PP50	38.9	101.6	44.5	36.5						GW210PP122	40.5	140	55.55	44.7	
W208PP50	31.78	72	36.5	18	W208PP51	38.9	101.6	44.5	36.5						GW210PP123	40.5	140	55.55	44.7	
W208PP51	31.78	72	36.5	18	W208PP52	38.9	101.6	44.5	36.5						GW210PP124	40.5	140	55.55	44.7	
W208PP52	31.78	72	36.5	18	W208PP53	38.9	101.6	44.5	36.5						GW210PP125	40.5	140	55.55	44.7	
W208PP53	31.78	72	36.5	18	W208PP54	38.9	101.6	44.5	36.5						GW210PP126	40.5	140	55.55	44.7	
W208PP54	31.78	72	36.5	18	W208PP55	38.9	101.6	44.5	36.5						GW210PP127	40.5	140	55.55	44.7	
W208PP55	31.78	72	36.5	18	W208PP56	38.9	101.6	44.5	36.5						GW210PP128	40.5	140	55.55	44.7	
W208PP56	31.78	72	36.5	18	W208PP57	38.9	101.6	44.5	36.5						GW210PP129	40.5	140	55.55	44.7	
W208PP57	31.78	72	36.5	18	W208PP58	38.9	101.6	44.5	36.5						GW210PP130	40.5	140	55.55	44.7	
W208PP58	31.78	72	36.5	18	W208PP59	38.9	101.6	44.5	36.5						GW210PP131	40.5	140	55.55	44.7	
W208PP59	31.78	72	36.5	18	W208PP60	38.9	101.6	44.5	36.5						GW210PP132	40.5	140	55.55	44.7	
W208PP60	31.78	72	36.5	18	W208PP61	38.9	101.6	44.5	36.5						GW210PP133	40.5	140	55.55	44.7	
W208PP61	31.78	72	36.5	18	W208PP62	38.9	101.6	44.5	36.5						GW210PP134	40.5	140	55.55	44.7	
W208PP62	31.78</																			

# Disc Harrow Bearings, Bearing Units and Hubs

9.1. Disc Harrow Bearings and Bearing Units

- Independent Discs..... 92

9.2. Integrated Hubs..... 93



## 9.1. Disc Harrow Bearings and Bearing Units – Independent Discs

Development of modern agricultural machinery has increased the demand of bearings for soil preparation machinery. There is a requirement that each disc should have its own compact bearing, in order to reduce the costs of dismounting and mounting during maintenance, as well as request for better sealing and permanent lubrication of bearings.

### Design

Design of double row angular contact ball bearings for agricultural application has derived from the design of the wheel bearings. Rigid bearing arrangement needs reduced and constant axial clearance that does not depend on the skills of final user but is provided by design and bearing production technology. Rings and balls are made of special bearing steel. One bearing is mounted on a single plate.

### Force

As opposite from classical disc harrow bearings, these bearings can support both axial force and torque.

### Sealing and lubrication

Bearing are permanently lubricated with grease for agricultural machinery at a rate of 60-80% of the free volume. These bearings have rubber-metal seals. It is also necessary to add the final sealing.

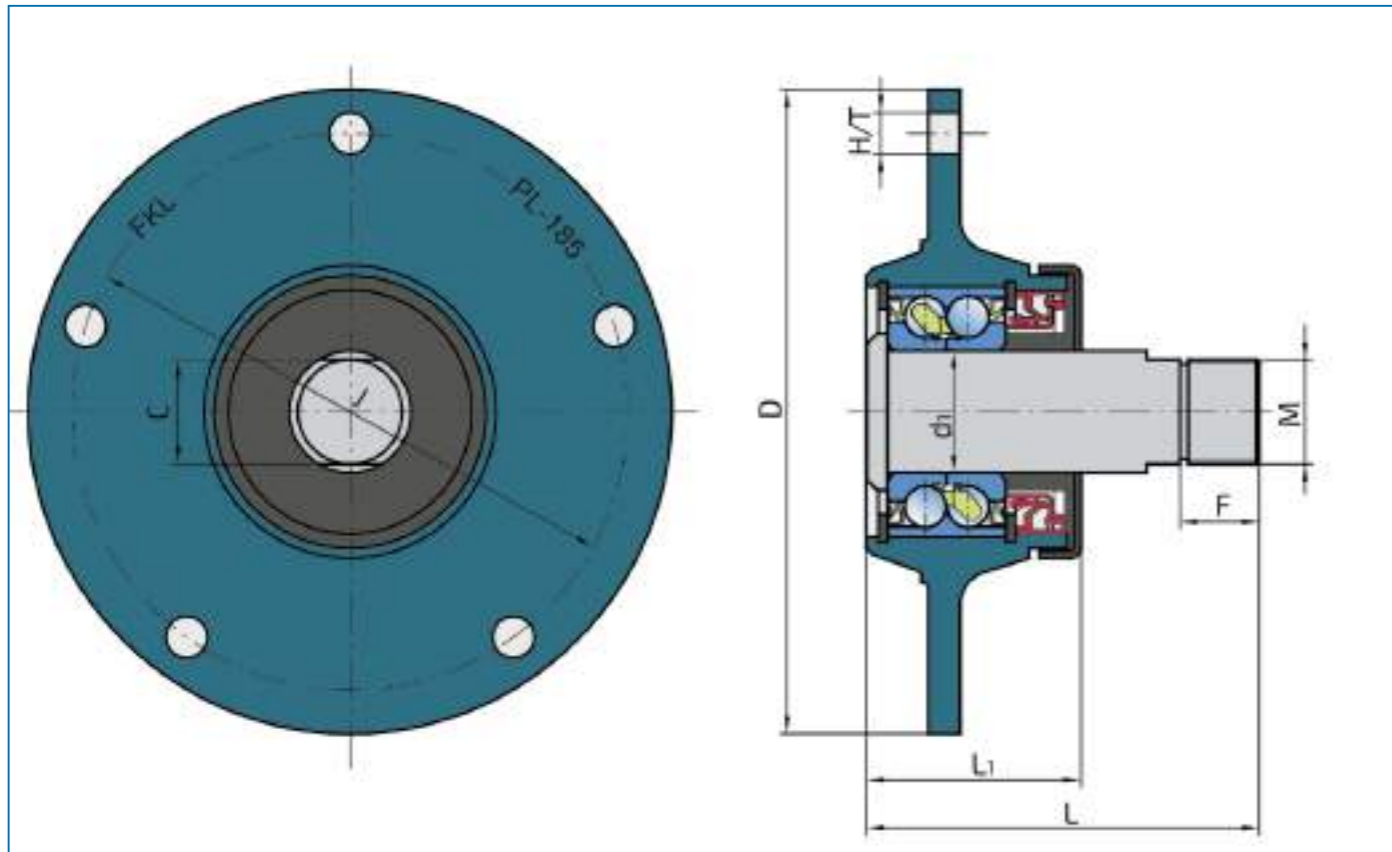

Fig.13. Disc harrow bearing

## 9.2. Integrated Hubs

In order to satisfy a modern tendency in agricultural equipment development, FKL has developed the Agro Point product line. Combined with disc this bearing hub is designed to work in various agricultural applications.

### Design

Depending on the application place, optimized internal hub design with integrated zinc coated flange provides a multiple service life of this type of product and good anticorrosion protection.

### Sealing and lubrication

Hubs are permanently lubricated with high quality grease for agricultural machinery at the rate of 60-80% of free volume which reduce the lubricant consumption and with its unique sealing solution reduces possible soil contamination.

### Advantages

Integrated Hubs product line is made as a long-term integral solution which doesn't require maintenance or service and simply to be replaced after its lifetime. Each model of hub has a certain loading capacity and basic dimensions, but mounting dimensions could be customer tailored solutions.

**Notice:** More about types, modalities and sizes of integrated hubs you can find in our leaflet AGRO POINT HUBS.

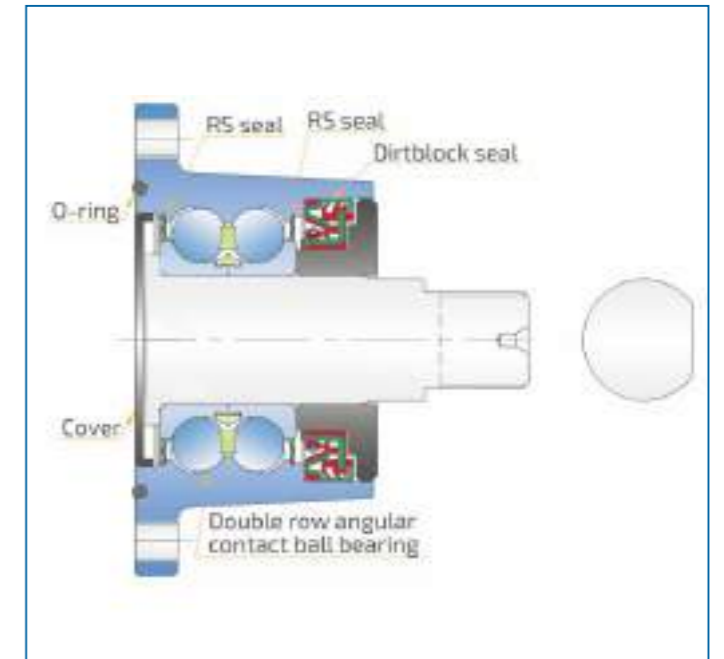
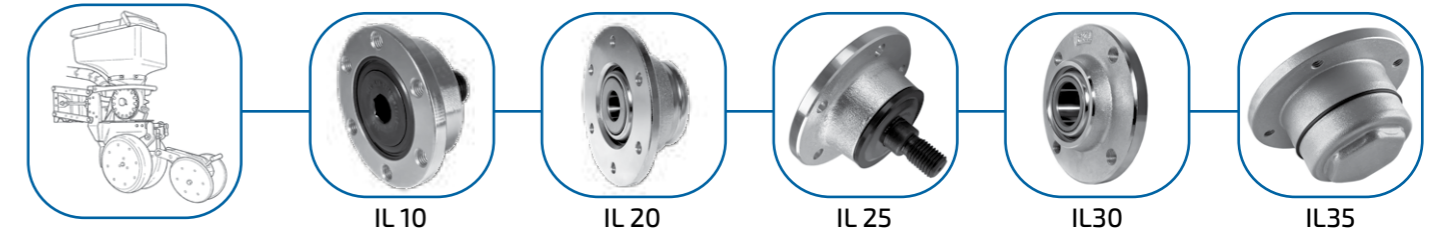
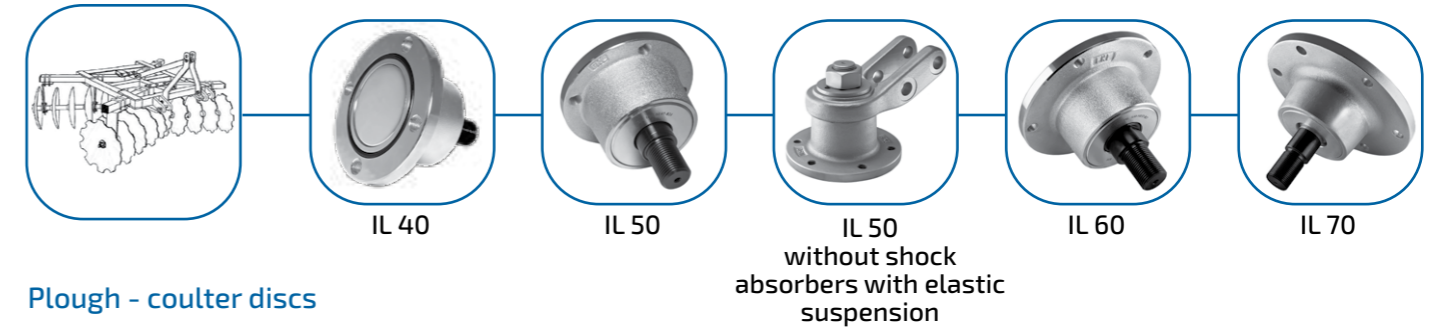

Fig.14. Technical drawing of Agro Point Hub IL50

### Seeding



### Tillage



### Plough - coulter discs

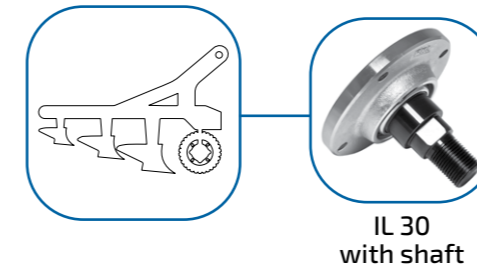



# Index Label

## 10.1. Index Label

Suffixes	
Sealing Types	
ZZ	Metal shield (non contact sealing) on both sides
2RS	One lip rubber metal seal on both sides
2RS1	One lip rubber metal seal on both sides
2L	The cover + protector (on both sides)
2S	One lip rubber metal seal (on both sides)
2F	One lip rubber metal seal + flinger, on both sides
2T	Three lip seal on both sides
T	Outer ring with stopping pin
2TC	Three lip seal on both sides+ metal cover
2TB	Three lip seal + metal shield, on both sides
TDT	Three lip seal at one side, double three lip seal on other side
FS	Sealing with one lip seal and a protective metal ring at one side and one lip seal on the another side
TBS	Sealing with three lip seal and a protective metal ring at one side and one lip seal on the another side
TBT	Sealing with three lip seal and a protective metal ring at one side and three lip seal on the another side
2P	Five lip seal on both sides
2PB	Five lip seal and metal shield, on both sides
2PC	Five lip seal on both sides + metal cover
P	Triple lip seal on one side, cylindrical surface of outer ring
PP	Triple lip seal, cylindrical surface of outer ring
PB	Triple lip seal on one side, spherical surface of outer ring
PPB	Triple lip seal, spherical surface of outer ring
RR	One lip seal cylindrical surface of outer ring
RRB	One lip seal spherical surface of outer ring
KPP	Triple lip seal cylindrical surface of outer ring
KPPB	Triple lip seal spherical surface of outer ring
KR	One lip seal on one side, cylindrical surface of outer ring
KRR	One lip seal, cylindrical surface of outer ring
KRB	One lip seal on one side, spherical surface
KRRB	One lip seal, spherical surface
KRP	One lip seal on one side and on the other side is triple lip seal
Special Surface Protection	
Zn	Galvanized: Zn1, Zn2, Zn6, Zn8, Zn9, Zn28,...
Br	Blackened: Br1, Br2, Br6, Br8, Br9, Br28,...
	1-... outer ring
	2-... inner ring
	6-... flinger
	8-... locking collar
	9-... all outside surfaces
	28-... inner ring + locking collar
Y Program - Special Design	
S0	For temperatures above normal (150°C)

Suffixes	
Geometry and Internal Design	
N	Snap ring groove in outer ring
NR	Snap ring groove in outer ring with snap ring
SH	Cylindrical outer ring without lubrication holes
L	Left hand thread
R	Right hand thread
C2	Radial internal clearance less than Normal
C3	Radial internal clearance greater than Normal
Q	Optimized contact geometry and surface finish
B	Contact angle 25°±5°
A	Hole for lubrication opposite of tightening
H	No lubrication hole
S	Cylindrical outer ring
SN	Groove for circlip
SNR	Groove with a circlip

Prefixes	
U	Version without eccentric collar
E	Tightening with locking screws
Y	Tightening with excenter rings
S	Compact fit tightening
K	Conrad, non filling slot type
FN	F Housing from Ductile Cast Iron
NN	N Housing from Ductile Cast Iron
SN	S Housing from Ductile Cast Iron
GR	Special round housing from Ductile Cast Iron
NR	Special oval housing from Ductile Cast Iron
HG	Special round housing from Ductile Cast Iron
HGR	Special round housing from Ductile Cast Iron
GW	With lubrication hole, wide ring single row
W	Permanently lubricated, wide ring single row
VP	Bearing with shaft
IL10-60	Agro Point Hub
PL	Hub with impressed bearing
LR	Track roller
SL	Special Ball Bearing
SLE	Special Ball Bearing
SLU	Special Ball Bearing
D	Special Ball Bearing
SLO	Special Ball Bearing
SLK	Special Ball Bearing
SP	Special Ball Bearing
SPR	Special Ball Bearing
TRB	Special Cylindrical Bearing

# 11. Production Program



## 12. FKL Distributors Worldwide

### Foreign Markets

#### LLC FKL

Russia, Voronezh  
Tel: +7 473 211 05 50  
www.rusfkl.ru

#### FKL BY

Belarus, Minsk  
Tel: +375 17 212 18 39  
www.fkl.by

#### FKL CZECH S.R.O.

Czech Republic/Slovakia, Kroměříž  
Tel: +420 573 33 68 60  
www.fkl-czech.cz

#### FKL HUNGARY KFT

Hungary, Debrecen  
Tel: +36 70 365 8187  
www.fklhungary.hu

#### FKL IBERICA Bearings S.L.

Spain/Portugal, Lugo  
Tel: +34 982 20 90 33  
www.fkl-iberica.com

#### FKL PARS

Iran, Tehran  
Tel: +98 21 77 50 64 61  
fkl.pars@gmail.com

#### FKL POLSKA SP.Z.O.O.SP.K.

Poland/Baltic States, Kuślin  
Tel: +48 605 48 68 78  
www.fkl-polska.pl

#### FKL ROMANIA SRL

Romania/Moldova, Bragadiru  
Tel: +40 374 64 02 27  
www.fklromania.ro

#### FKL UKRAINE LTD

Ukraine, Lutsk  
Tel: +38 332 77 43 99  
www.fkl.ua

#### AGRIPARTNER - GANAYE SARL

France, Beaumont  
Tel: +33 05 49 85 50 22  
www.agripartner.fr

#### AS MODUATOR

Estonia, Põltsamaa  
Tel: +372 776 86 53  
www.moduator.ee

#### AUCKLAND BEARING DISTRIBUTORS LTD

New Zealand, Auckland  
Tel: +64 9 444 65 66  
www.aucklandbearings.co.nz

#### CELSAN EUROPA S.R.L.

Italy, Argelato  
Tel: +39 51 66 30 741  
www.celsan.com

#### COMPENSA HANDEL GMBH

Austria, Wien  
Tel: +43 1 982 14 39 23  
www.compensa.at

#### EKOAL OOD

Bulgaria, Razgrad  
Tel: +359 84 66 08 71  
www.ekoalbg.com

#### HAGOP GIRAGOS

Syria, Lattakia  
Tel: +963 41 43 31 08  
giragos@scs-net.org

#### JOKILAAKERI OY

Finland, Pori  
Tel: +358 2 631 95 00  
www.nomogroup.fi

#### LAUDORTS SIA

Latvia, Riga  
Tel: +371 20 52 15 59  
www.laudorts.lv

#### LIETZ ANTRIEBSTECHNIK GMBH & CO. KG

Germany, Heckelberg-Brunow  
Tel: +49 33451 555 05  
www.lietz-at.de

#### NOVOTECHNO S.R.O.

Slovakia, Nové Zámky  
Tel: +421 35 6424 520  
www.novotechno.sk

#### PO BEARINGS S.R.O.

Slovakia, Prešov  
Tel: +421 51 74 950 86  
www.loziska-bearings.sk

#### ROLLER J KOUKORINIS J LIAKOPOULOS EE

Greece, Larissa  
Tel: +30 2410 28 91 39  
www.roller.com.gr

#### SE-KRA DOO

Croatia, Sesvetski Kraljevec  
Tel: +385 01 204 80 23  
www.se-kra.hr

#### SISA OTOMOTIV DIS TICARET LTD

Turkey/Iraq, Izmir  
Tel: +90 232 375 22 81  
sisa.dis.tic@superonline.com

#### SRL ROMANCIUC ROMA SI CO

Moldova, Singerei  
Tel: +373 69 16 83 82  
romanciuci@mail.ru

#### TEMKO DOO

North Macedonia, Skopje  
Tel: +389 2 3066 068  
goran.temko@gmail.com

#### TIVI GROUP LTD

Bulgaria, Dimitrovgrad  
Tel: +359 391 61 561  
www.tivigroup.com

#### UAB IGNERA

Lithuania, Kaunas  
Tel: +370 37 35 35 15  
www.ignera.lt

#### VSC UNITECH SRL

Moldova, Chişinău  
Tel: +373 69 10 16 79  
www.vscunitech.md

#### VULIN DOO

Bosnia and Herzegovina, Bijeljina  
Tel: +387 55 49 03 40  
vulindoo@yahoo.com

#### WEARPARTS TILLAGE TOOLS

USA, Gothenburg  
Tel: +1 888 425 2337  
www.wearpartslc.com

### Domestic Market

#### MIKRON DOO

Serbia, Sirig  
Tel: +381 21 849 538  
www.mikron-doo.rs

#### NEPTUN DOO

Serbia, Temerin  
Tel: +381 21 84 62 55  
www.neptundoo.rs

#### TENEJ DOO

Serbia, Beograd  
Tel: +381 11 74 65 655  
www.tenej.com

#### AGROMARKET DOO

Serbia, Veternik  
Tel: +381 21 82 34 24  
www.agromarket021.com

### Domestic Subdistributors

#### JUSEL DOO

Serbia, Šabac  
Tel: +381 15 30 00 00  
www.jusel.com

#### KUGLAGER DOO

Serbia, Novi Sad  
Tel: +381 21 63 93 130  
www.kuglager.rs

#### LAGERTON DOO

Serbia, Niš  
Tel: +381 18 57 63 62  
www.lagerton.com

#### SET TRADE N&N DOO

Serbia, Zrenjanin  
Tel: +381 23 52 34 00  
settradenn@gmail.com

Copyright © 2022 FKL. All rights reserved.

These contents are the copyright of the publisher and may not be reproduced, in total or partially, without express consent of the publisher. Every precautions were taken to ensure the accuracy of the information in this publication but no liability can be accepted for any errors or omissions.

Prepared in Factory of rolling bearings and cardan shafts Temerin, Serbia

Editor in Chief: Ljiljana Marić, B. Sc. Economics and Dejan Zrilić, B. Sc. Economics

Copy Editor: Laslo Koman, B. Sc. Mechanical Engineer; Biljana Obrenović, Master in Mechanical Engineer and Jovan Tomić, B. Sc. Mechanical Engineer

Photos, Layout and Prepress: Monja Madić, Master in Graphic Engineer and Design and Oleg Vorobev, Industrial product designer

Print: MAXIMA Graf, June 2022.